

XOMOX[®]

brands you trust.

Technical Datasheet **XOMOX[®] XLD Fully Lined Butterfly Valve**



Crane ChemPharma & Energy

www.cranecpe.com

Design Features

The XOMOX[®] lined butterfly valve is available in DIN under the term XLD12 as wafer version and XLD22 as lug version. The ASME types are termed XLD11 as wafer version and XLD21 as lug version, and in JIS as XLD13 wafer version and XLD23 lug version.

For XOMOX[®] Lined Butterfly Valves bi-directional flow is possible at max. operating pressure. Since the valve port corresponds to the piping diameter, a high flow capacity is guaranteed.

The seamless one piece molded liner together with the underlying elastic O-ring provides trouble- and maintenance-free operation. It covers the lower shaft completely and renders an additional sealing to atmosphere unnecessarily.

The liner extends up the shaft to above the secondary seal. This sealing prevents leakage to atmosphere. The body seal ring is designed to provide a 360° sealing for in-line shutoff and at the upper and lower shaft to act as primary seal to atmosphere.

A further special feature is the one-piece disc consisting of a metallic core (disc/shaft) with a homogeneous non-porous plastic coating standing up to the secondary external seals.

All these features combine to make the XOMOX[®] lined butterfly valve the solution for tight shutoff and corrosion resistance and represent an advance on all previously available products of this type.

Each valve is 100% spark tested with 20000 volts in accordance with API 598 specification to ensure the absence of pin holes and defects.

Key Benefits

- Superior In-Line Sealing– Viton ring activated PFA liner is more flexible than larger sintered PTFE liners which allows for improved inline sealing, protecting equipment from internal corrosion related to media leakage.
- Longer Valve Life– PFA lasts 20% longer than PTFE due to abrasion resistance helps to improve life of inline seal.
- PFA lining more robust in thermal cycles and high temperature applications (>180°C) than PTFE lining allowing the PFA lined disk to last longer keeping the chemical plant operating longer.

Scope of Supply

Materials

- **Body:** Ductile iron EN-JS1049/ASTM A395
- **Body liner:** PFA
- **Disc:** 2"-12": Ductile iron EN-JS1049 / ASTM A395 PFA lined & SS PFA lined, 14"-24": Fabricated Disc (A516 Gr. 70+ 1.4462/ F51/F60 SS Duplex Stem) PFA lined
- **Face to face** acc. to EN 558, basic column 20/ API 609 (except for 14")

Operation

DN 50 / NPS 2 up to DN 150 / NPS 6 latching lever from DN 200 / NPS 8 with worm gear, pneumatic and electric actuators on request.

Tightness

The actual leakage rate to atmospheric pressure is less than 1·10⁻⁶ mbar · l/s of helium gas. Requirements according to TA-Luft specification will be accomplished.

Paint

Standard paint: Epoxy - primer and coating based on AY-PUR (Acryle-Polyuretane) Orange RAL 2009, FV7133 prevent external corrosion

Design Features

Type test approval VdTÜV-M229 for plants subject to inspection:

Rule	Dampfkv	DruckbehV	Gas HL-V0	VbF
Code	TRD	TRB/TRR	TRGL/DVGW	TrbF

Options:

- Chlorine application
- Oxygen application
- Disc in stainless steel or Titanium (without lining)
- O-ring Silicon
- Safety manual adjustable packing
- PFA antistatic lining
- PTFE Liner / PTFE lined disc from DN350 size onwards
- Other painting on request

XLD Pressure/Temperature Rating

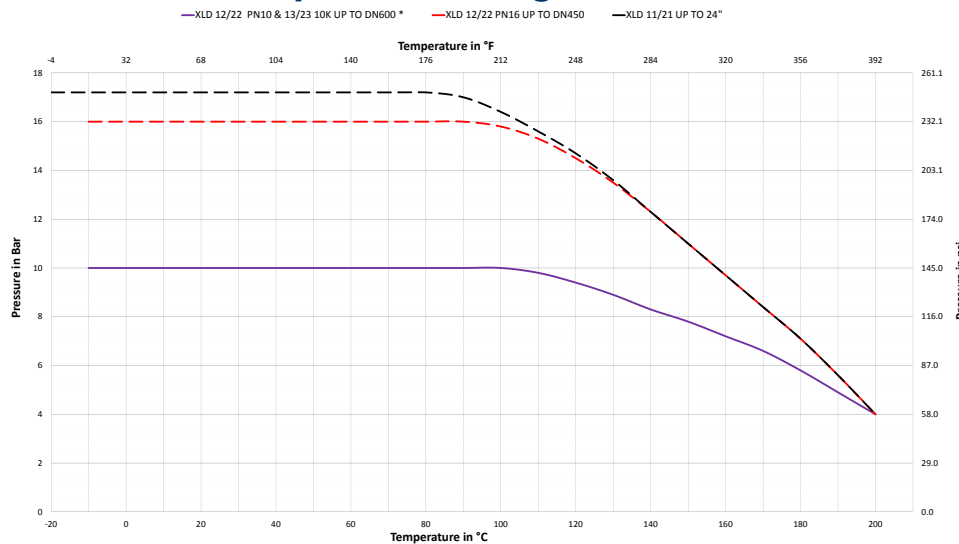

Note: Max. differential operating pressure limited to maximum of 10bar for all sizes
 * XLD 13 / 23 10K UPTO DN500

All XLD in Vacuum Condition

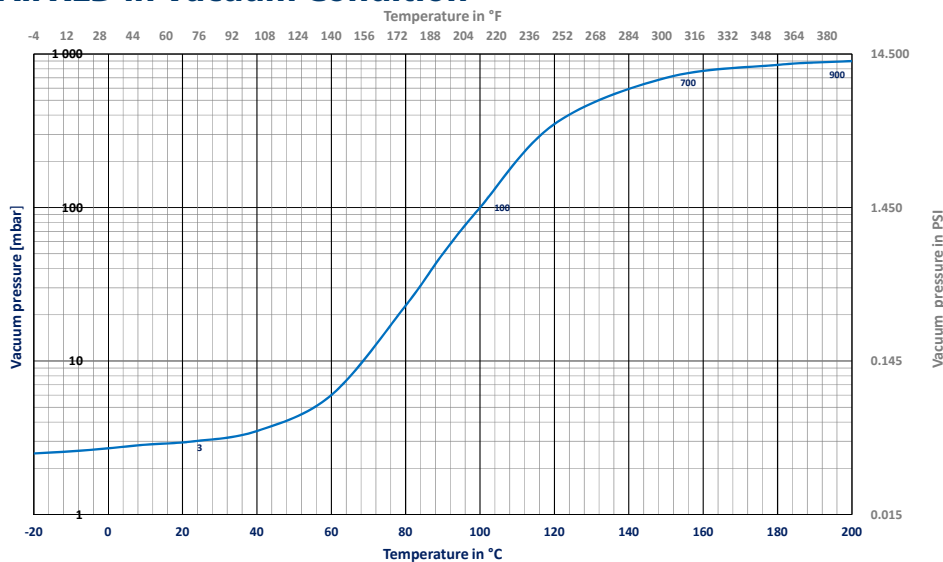

Materials of Construction

Item	Quantity	Part	Material
1	1	Atmospheric seal	PTFE Teflon [®]
2	1	Snap Ring	304 SS
3	1	Thrust Collar	1.4408 / 1.4541 / 304 SS / 1.4571
4	1	Washer Spring Set	17/7 PH
5	1	Gland	1.4571
6	3	O-Ring	FKM
7	2	Spacer	1.4571
8	1	Body Top half	EN-JS1049/ASTM A395 PFA liner
9	1	Body Bottom half	EN-JS1049/ASTM A395 PFA liner
10	2	Body Seal Ring	FKM
11	1	Liner	PFA
12	1	Disc	DN 50-300: EN-JS1049/ASTM A395 or SS PFA lined DN 350-600: Welded Disc (A516 Gr. 70+ 1.4462/F51/F60 SS Duplex Stem) PFA lined
13	2	Nut	A4-70 (108/109, 808/809) , A194 2H (008/009)
14	1	Snap Ring	304 SS
15	2	Split Sleeve	1.0904 A26
16	2/4	Washer	1.4301
17	2	Body Bolt	A4-70 (108/109, 808/809) , A193 B7 (008/009)
18	2	Bolt	A4-70 (108/109, 808/809) , A193 B7 (008/009)
19	1	Stuffing Box Flange	1.4408
20	2	Nut	A4-70 (108/109, 808/809) , A194 2H (008/009)
21	2	Laminated Shim	-
22	2	Slotted Spring Pin	1.4310
23	2	O D Ring	304 SS

DN 50/2" – 300/12"

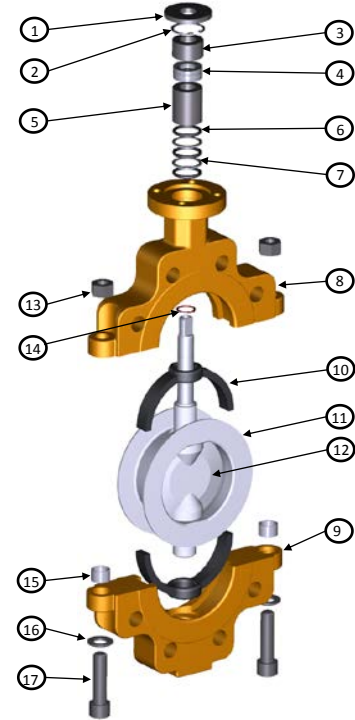

DN 350/14" – 600/24"

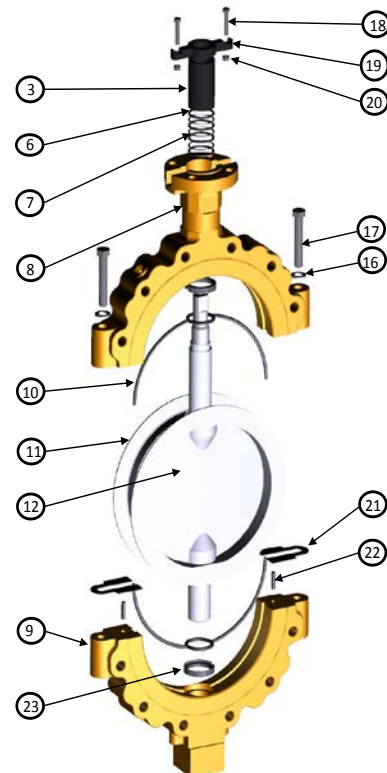

Sealing Principles

1. In-line seal – valve in closed position

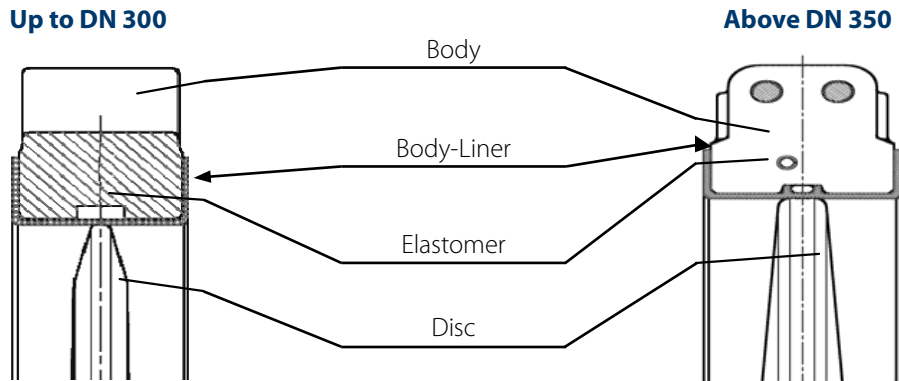

2. In-line seal – valve in opening position

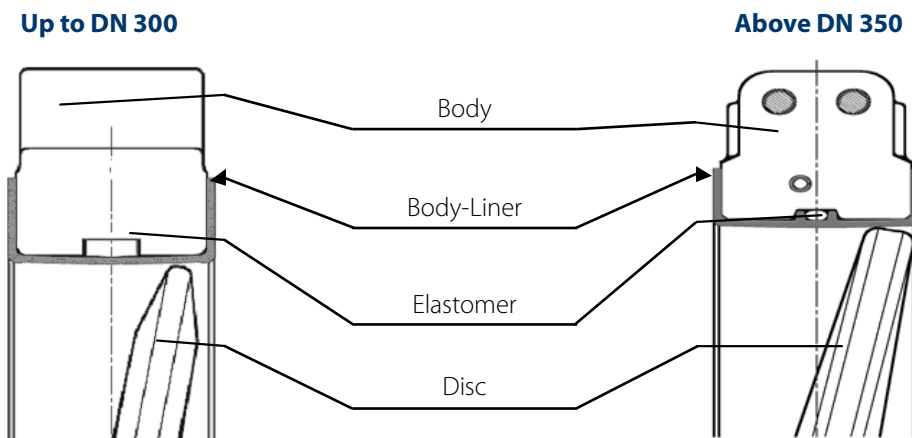

3. Secondary shaft seal

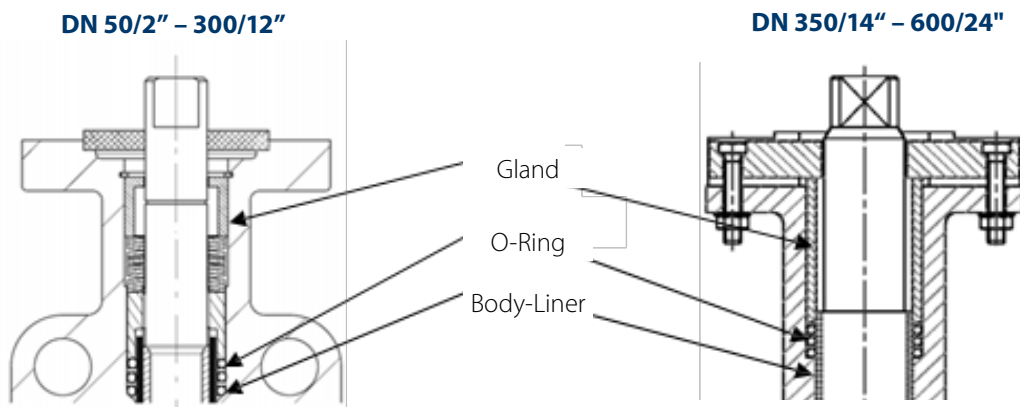

Flow Characteristics

Kv values in m³/h, Cv=1,156 Kv

Angel of Aperture	0°	9°	18°	27°	36°	45°	54°	63°	72°	81°	90°
Angel of Aperture %	0	10	20	30	40	50	60	70	80	90	100
DN / NPS											
50 / 2	0	0.62	2.6	12	30	65	95	135	165	170	180
80 / 3	0	0.82	3.6	14.4	38	70	112	166	212	228	233
100 / 4	0	1.5	5.8	22	55	102	177	296	408	464	486
125 / 5	0	4.6	13	40	92	164	267	413	564	698	790
150 / 6	0	12.12	31	82	183	296	415	595	834	1115	1445
200 / 8	0	18.4	44	130	280	435	640	910	1282	1705	2227
250 / 10	0	27.3	65	200	410	660	958	1345	1912	2550	3320
300 / 12	0	40.7	99	295	596	965	1396	1975	2827	3795	4908
350 / 14	0	68	216	413	720	1225	1944	2890	4104	5520	7200
400 / 16	0	90	268	518	895	1535	2416	3663	5100	6960	8950
450 / 18	0	116	340	660	1135	1934	3065	4610	6470	8810	13350
500 / 20	0	164	415	822	1390	2400	3750	5670	7925	10700	13900
600 / 24	0	231	570	1060	1900	3250	5130	7790	10830	14440	19000

DN65 NPS 21/2 on request

Valve coefficients for process control: DN 50 – 200 / NPS 2 – 8

Angel of Aperture	9°	18°	27°	36°	45°	54°	63°	72°	81°	90°
Angel of Aperture %	0.10	0.20	0.30	0.40	0.50	0.60	0.70	0.80	0.90	1.00
Recovery factor FL	0.85	0.85	0.85	0.85	0.81	0.73	0.67	0.61	0.59	0.55
Factor F_L^2	0.72	0.72	0.72	0.72	0.66	0.53	0.45	0.37	0.35	0.30
Valve characteristic z_y	0.47	0.47	0.47	0.47	0.43	0.37	0.33	0.28	0.27	0.24
Pressure differential ratio kT	0.61	0.61	0.61	0.61	0.55	0.45	0.38	0.31	0.29	0.25
Valve style modifier F_d	0.08	0.15	0.23	0.31	0.38	0.45	0.52	0.58	0.64	0.70

Valve coefficients for process control: DN 250 – 600, NPS 10 – 24

Angel of Aperture	9°	18°	27°	36°	45°	54°	63°	72°	81°	90°
Angel of Aperture %	0.10	0.20	0.30	0.40	0.50	0.60	0.70	0.80	0.90	1.00
Recovery factor FL	0.80	0.82	0.82	0.82	0.78	0.67	0.56	0.51	0.48	0.42
Factor F_L^2	0.64	0.67	0.67	0.67	0.61	0.45	0.31	0.26	0.23	0.18
Valve characteristic z_y	0.43	0.44	0.44	0.44	0.41	0.33	0.25	0.22	0.20	0.16
Pressure differential ratio kT	0.54	0.56	0.56	0.56	0.51	0.38	0.26	0.22	0.19	0.15
Valve style modifier F_d	0.08	0.15	0.23	0.31	0.38	0.45	0.52	0.58	0.64	0.70

In-Line Mounting Dimensions

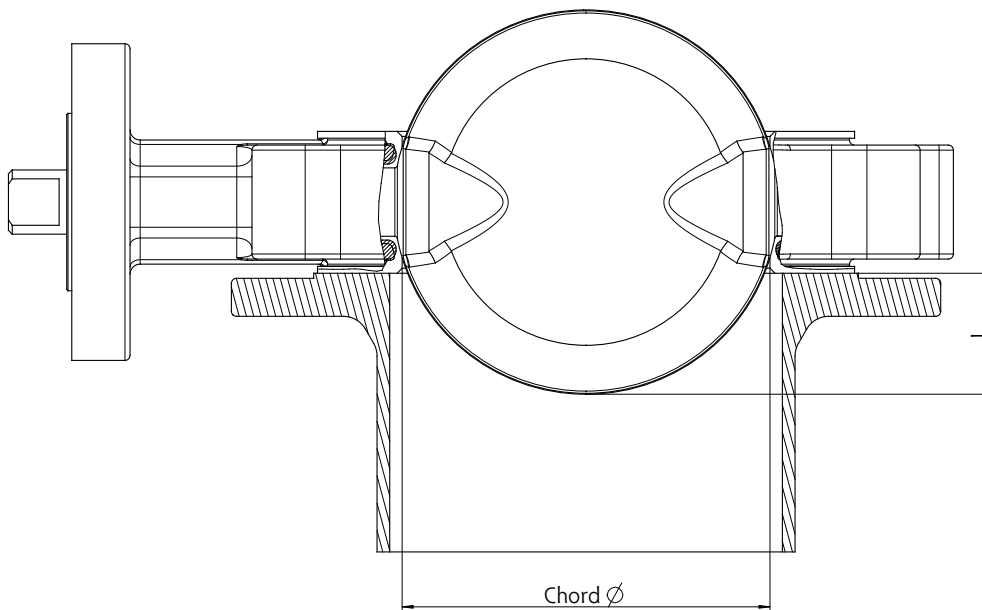

Valve coefficients for process control: DN 50 – 200 / NPS 2 – 8

DN	NPS	In-line mounting dimensions		Free space sectional area at 90° in cm ²	ξ ₁	Break-away torque in Nm	Maximal Allowable torque on stem in Nm
		Dimension L in mm	Chord Ø mm		*1	*2	*4
50	2	8	29	10.6	3.2	35	162
80	3	16	62	24.7	2.4	35	162
100	4	25	88	51.8	0.85	50	162
125	5	37	114	89.2	0.72	62	162
150	6	49	141	138	0.45	94	296
200	8	72	193	255.2	0.53	209	628
250	10	93	245	411.3	0.58	242	628
300	12	113	294	610.6	0.55	308	628
350	14	124	325	709.5	0.45	900	2432
400	16	144	375	923.3	0.50	1300	2432
450	18	163	425	1201.1	0.50	1700	5655
500	20	181	475	1527.7	0.51	2700	5765
600	24	218	570	2306.6	0.56	4000	11649

DN65 NPS 2 1/2 on request

*1 Coefficient of resistance, acc. to theoretical pipe diameter (DN) and K_{va} (opening angle 90°)

*2 Identical torque at opening and closing, running torque = 40% of break away torque

*3 Max. Permissible torque with Material EN-JS1049 up to DN300 & with 1.4462 SS from DN 350 onwards

Dimensions with Bare Shaft DN 50-300, 2" - 12"

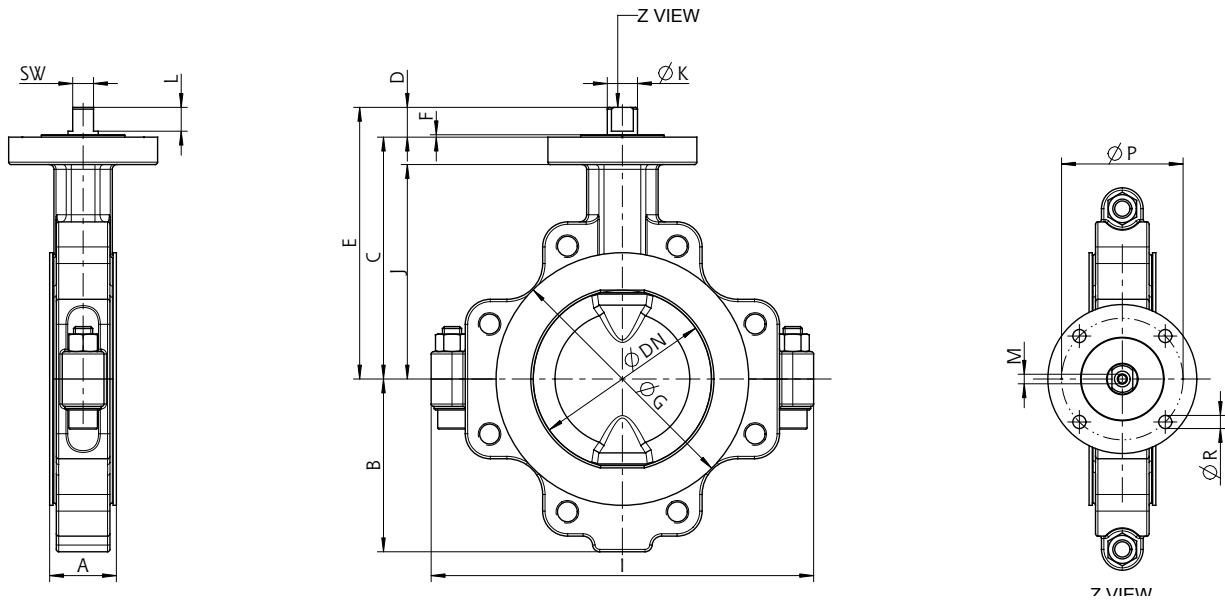

Dimensions (mm) and Weight (kg)

DN NPS	50 2	65 2 1/2	80 3	100 4	125 5	150 6	200 8	250 10	300 12
A	43	46	46	52	56	56	60	68	78
B	81	87	102	120	135	145	190	233	258
C	133	146	160	170	185	203	230	258	288
D	30	30	22	26	29	25	26	26	30
E	163	176	182	196	214	228	256	284	318
F	3	3	3	3	3	3	3	3	3
ØG	100	128	127	153	184	212	265	324	374
J	119	135	138	154	166	180	210	231	266
I	168	175	223	267	295	321	394	462	552
ØK	15.9	15.9	15.9	15.9	15.9	25.4	31.8	31.8	31.8
SW	11.1	11.1	11.1	11.1	11.1	17.5	20.6	20.6	20.6
L	25	25	17	21	24	20	21	21	25
M	M6	M6	M6	M6	M6	M8	M8	M8	M8
DIN ISO 5211	F07	F07	F07	F07	F074	F10	F10	F10	F12
ØP	70	70	70	70	70	102	102	102	125
ØR	9	9	9	9	9	11	11	11	14
Weight	7.5	7.5	7.5	9.5	12.0	15.0	25.0	33.0	53.0

Dimensions with Bare Shaft DN 350 – 600, NPS 14 – 24

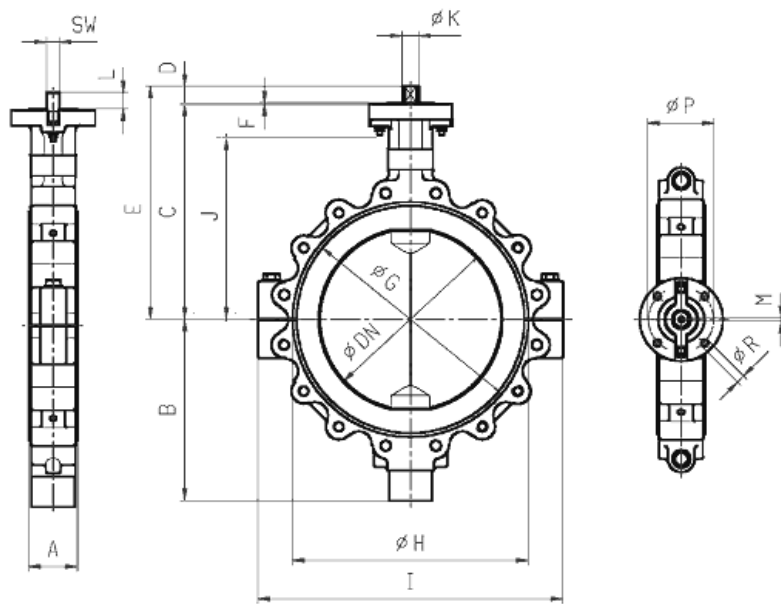

Dimensions (mm) and Weight (kg)

DN NPS	350 14	400 16	450 18	500 20	600 24
A	92	102	114	127	154
B	353	380	410	460	520
C	417	452	470	500	560
D	38	38	60	60	65
E	455	490	530	560	625
F	3	3	5	5	5
ØG	415	480	530	580	684
J	576	640	676	740	880
I	345	380	393	423	468
ØK	36	36	48	48	60
SW	27	27	36	36	46
L	35	35	55	55	62
M	M8	M8	M12	M12	M12
Actuator Connection					
DIN ISO 5211	F14	F14	F16	F16	F16
ØP	140	140	165	165	165
ØR	18	18	22	22	22
Weight	102	127	176	202	308

Flange Bolt Dimensions

Drilling DIN PN 10 (mm)

Size	XLD 10/16 Wafer Style			XLD 22 Lug Style		
	F	G	H	F	G	H
DN 50	125	4	18	125	4	M16
DN 65	145	4	18	145	4	M16
DN 80	160	8	18	160	8	M16
DN 100	180	8	18	180	8	M16
DN 125	210	8	18	210	8	M16
DN 150	240	8	22	240	8	M20
DN 200	295	8/12	22	295	8/12	M20
DN 250	350/355	12	22/26	350/355	12	M20/24
DN 300	400/410	12	22/26	400/410	12	M20/24
DN 350	460/470	16	22/26	460/470	16	M20/24
DN 400	515/525	16	26/30	515/525	16	M24/27
DN 450	565/585	20	26/30	565/585	20	M24/27
DN 500	620	20	26	620	20	M24
DN 600	725	20	30	725	20	M27

Drilling JIS 10 K 10 (mm)

Size	XLD 13 Wafer Style			XLD 13 Lug Style		
	F	G	H	F	G	H
DN 50	120	4	19	120	4	M16
DN 65	140	4	19	140	4	M16
DN 80	150	8	19	150	8	M16
DN 100	175	8	19	175	8	M16
DN 125	210	8	23	210	8	M20
DN 150	240	8	23	240	8	M20
DN 200	290	12	23	290	12	M20
DN 250	355	12	25	355	12	M22
DN 300	400	12+4	25/22	400	16	M22
DN 350	445	16	25	445	16	M22
DN 400	510	16	27	510	16	M24
DN 450	565	20	27	565	20	M24
DN 500	620	20	27	620	20	M24
DN 600	N/A	N/A	N/A	-	-	-

Drilling ANSI Pressure Class 150 (in)

Size	XLD 11 Wafer Style			XLD 21 Lug Style		
	F	G	H	F	G	H
2"	4.75	4	0.75	4.75	4	5/8-11 UNC
3"	6	4	0.75	6	4	5/8-11 UNC
4"	7.5	8	0.75	7.5	8	5/8-11 UNC
5"	8.5	8	0.88	8.5	8	3/4-10 UNC
6"	9.5	8	0.88	9.5	8	3/4-10 UNC
8"	11.75	8	0.88	11.75	8	3/4-10 UNC
10"	14.25	12	1	14.25	12	7/8-9 UNC
12"	17	12	1	17	12	7/8-9 UNC
14"	18.75	12	1.13	18.75	12	1"-UNC
16"	21.25	16	1.13	21.25	16	1"-UNC
18"	22.75	16	1.25	22.75	16	1 1/8"-8UN
20"	25	20	1.25	25	20	1 1/8"-8UN
24"	29.5	20	1.37	29.5	20	1 1/4"-8UN

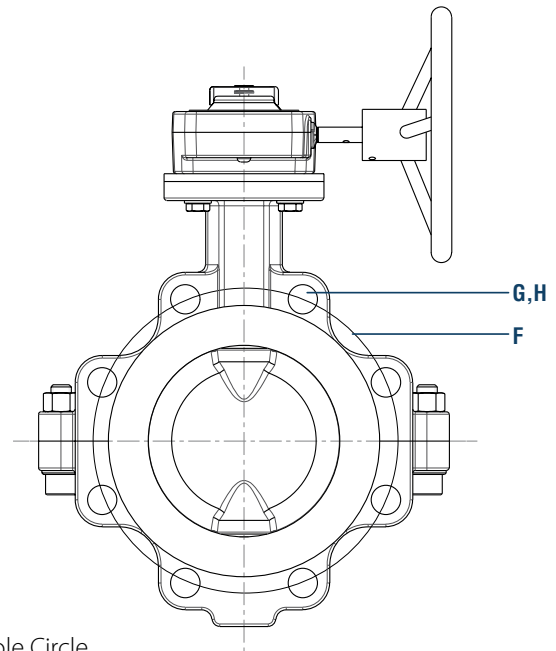

F: Hole Circle
 G: Number of Holes/Threads
 H: Diameter of Hole/Thread Dimension

Dimensions with Latching Lever

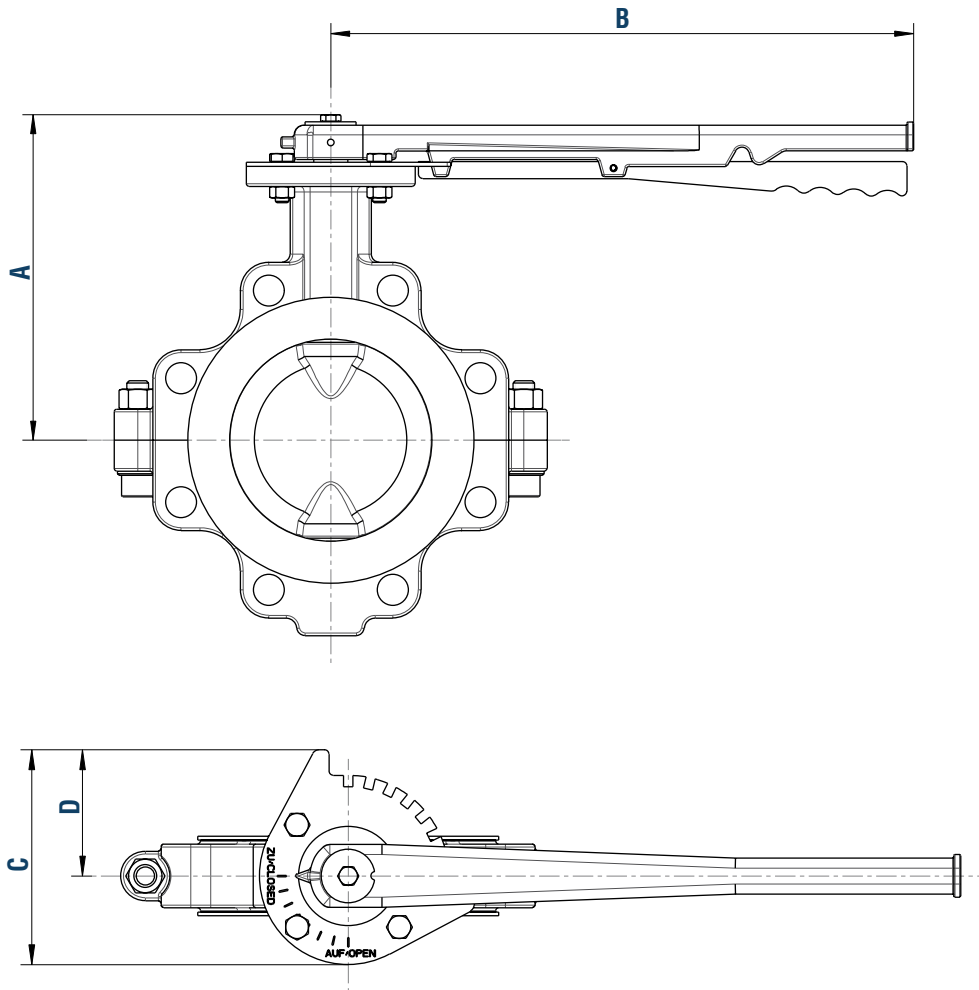

Lever design:

- **Lever:** ENJS 1049 (GGG 40.3); zinc - phosphate coated
- **Notch plate:** 1.4571
- **Screws:** A4 - 70
- **Nuts:** A4

Dimensions (mm) and Weight (kg)

DN NPS	50 2	65 2.5	80 3	100 4	125 5	150 6	200 8
A	173	186	192	208	225	245	301
B	356	356	356	356	356	432	432
C	134	134	134	134	134	134	134
D	89	89	89	89	89	89	89
Weight	8.5	9	9.5	11.5	14	17.5	27.5

Dimensions with Gear DN 50 – 300, NPS 2 – 12

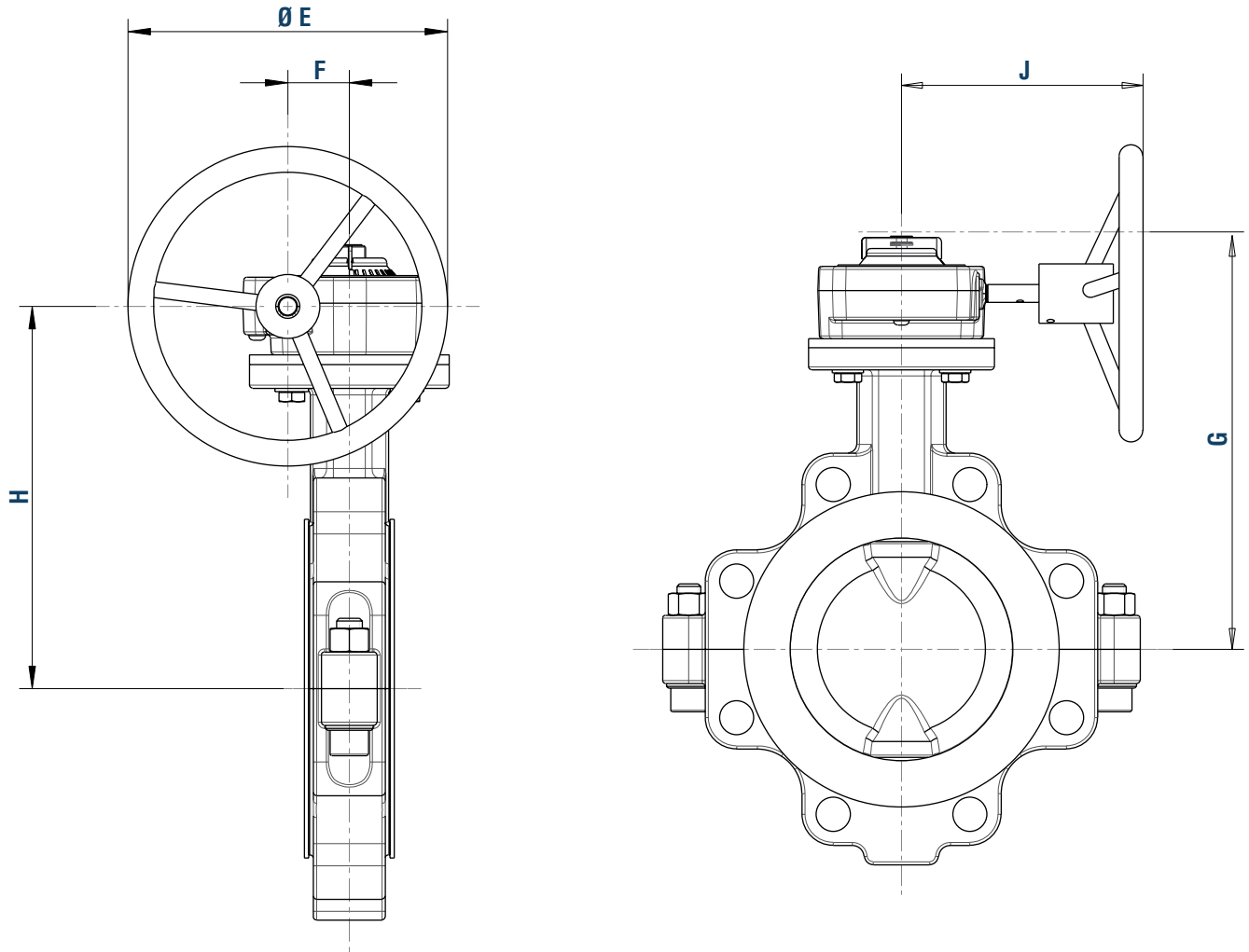

Gear design:

- **Standard:** Alu-Gear (aluminium-molded, chromed) Screws: A4-70;
- **Wheel:** EN 10025 (1.0038), powder coated

Dimensions (mm) and Weight (kg)

DN NPS	50 2	65 2.5	80 3	100 4	125 5	150 6	200 8	250 10	300 12
ØE	125	125	125	125	125	203	203	203	203
F	38.5	38.5	38.5	38.5	38.5	46.5	60	60	60
G	188	201	207	223	241	260	289	314	401
H	163	173	179	196	211	228	257	283	369
J	134	134	134	134	134	180	205.5	205.5	205.5
Weight	8	8.5	9	11	13.5	17.5	29.3	36	58

Dimensions with Gear DN 350 – 600, NPS 14 – 24

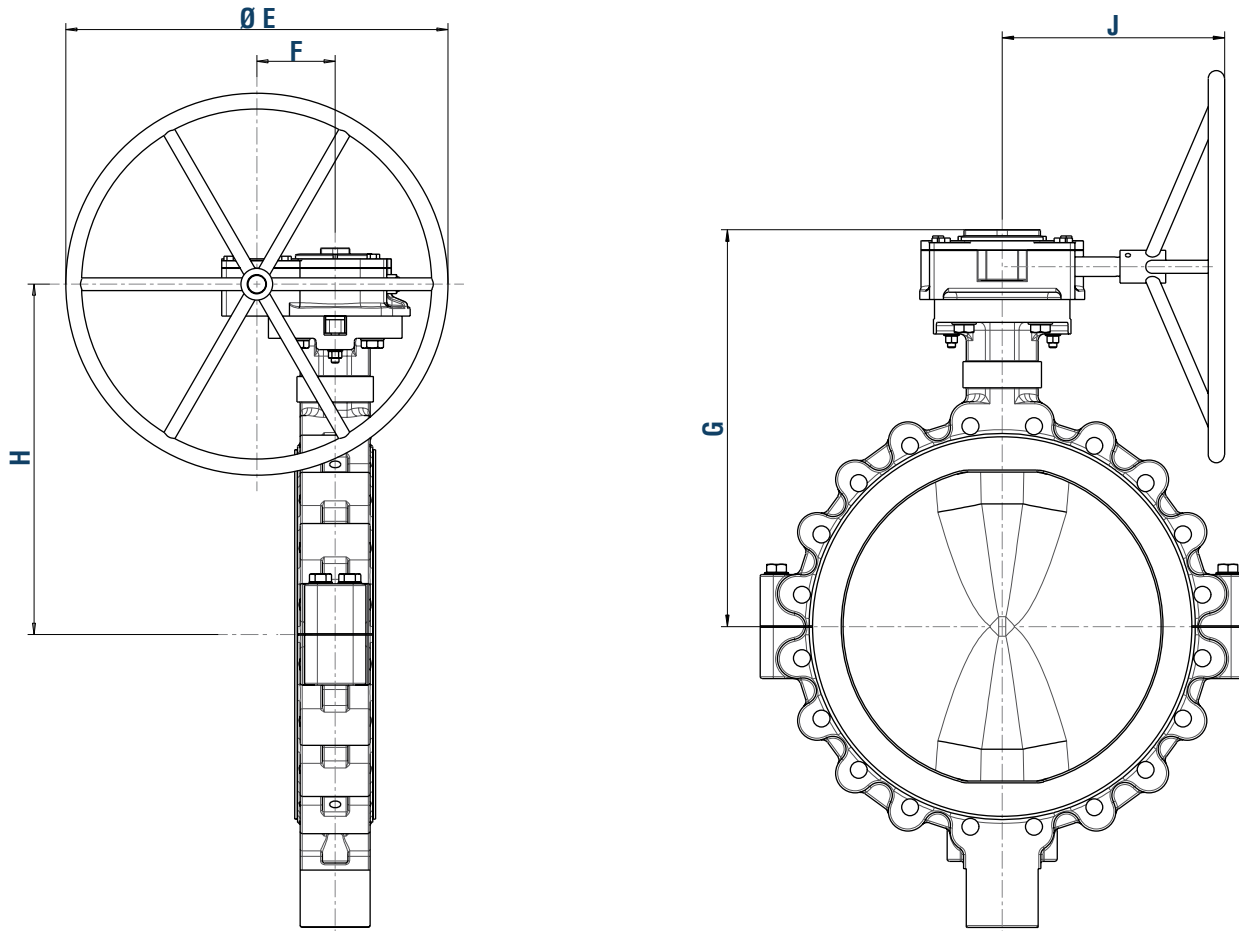

Dimensions (mm) and Weight (inkl. MG)

DN NPS	350 14	400 16	450 18	500 20	600 24
ØE	457	457	457	610	610
F	66.7	66.7	89.5	123	123
G	498	533	563.5	605.5	665.5
H	459	494	520	550	610
J	223	223	278	310	310
Weight	115	140	195	238	341

Dimensions with Actuator

Direct mounting

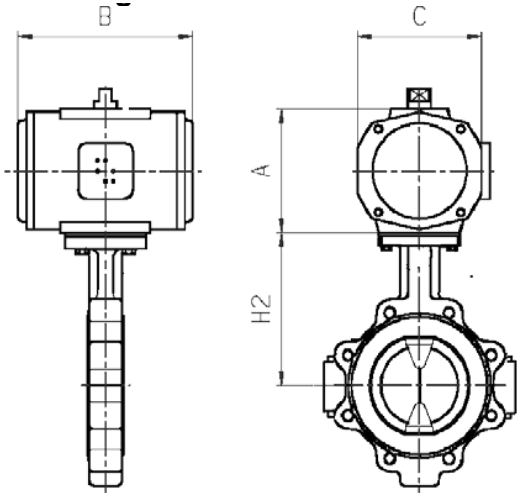

With bracket and coupling

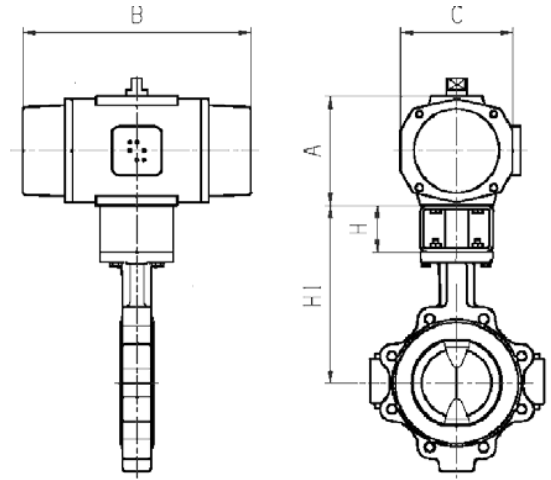

Single acting pneumatic actuators

DN	A	B	C	H1	H2	H	Direct mounting
50	143	360	128	213	133	80	Yes
80	143	360	128	232	152	80	Yes
100	143	360	128	248	168	80	Yes
125	143	360	128	265	185	80	Yes
150	181	387	173	279	199	80	Yes
200	259	517	231	318	N/A	90	No
250	259	517	231	344	N/A	90	No
300	259	517	231	430	N/A	90	No

DN65 NPS21/2 on request

Single acting pneumatic actuators

DN	A	B	C	H1	H2	H	Direct mounting
50	93	180	86	193	133	60	Yes
80	93	180	86	212	152	60	Yes
100	105	199	98	228	166	60	Yes
125	118	221	108	247	184	60	Yes
150	143	283	128	279	198	80	Yes
200	181	305	173	308	226	80	Yes
250	181	305	173	334	254	80	Yes
300	181	305	173	368	288	80	Yes

DN65 NPS21/2 on request

These dimensions refer to standard pneumatic actuators with 4 bar pressure. Please be aware that these data can therefore only be used for general actuator sizing purposes within piping systems. Actuator sizing above DN 300 on request.



Teflon® is a registered Trademark of I. E. du Pont de Nemurs and Company and is used under license by XOMOX® International GmbH & Co.

XLD Lined Butterfly Valve Applications

CRANE ChemPharma & Energy, XOMOX® XLD Lined Butterfly Valve - Performance Chart

FUNCTION	On / Off	●
	Throttling	●
	Diversion	●
MEDIA TYPES	Clean Liquids & Gases	●
	Dirty Liquids & Gases	●
	Corrosive Liquids & Gases	●
	Hazardous Liquids & Gases	●
	Viscous Liquids	●
	Scaling Liquids & Slurries	●
	Abrasive Slurries	●
	Fibrous Slurries	●
	Dry Materials	●
	Vacuum Service	●
APPLICATION REQUIREMENTS	High Flow Capacity	●
	Low Torque	●
	Fugitive Emissions Control	●
	Reduced Maintenance	●
	Extended Service Life	●
	Sizes	2"-24" DN50-DN600
	Pressure Ratings	Class 150 / PN 10 PN 20
	High Temperature (ASME/EN)	200°C / 392°F
	Low Temperature (EN)	-10°C / 14°F
	Low Temperature (ASME)	-20°C / -4°F
Key Benefit	Safety / Economy	

- Superior Performance
- Limited Application
- Not Applicable

Source: CRANE Engineering

XLD valves offer economical solutions for the vast majority of chemical applications while maintaining the highest possible degree of performance in terms of in-line leakage and fugitive emissions.

XLD valves are commonly used within the following industries:

- Chlor-Alkali
- Industrial Inorganic Chemicals
- Metal and Mining
- Nitrogen and Phosphatic Fertilizers
- Petroleum Refining
- Pharmaceutical

Within these industries, XLD valves have superior performance in the following applications:

- Chlorine
- Benzene
- Bromine
- Sulfuric Acid
- Nitric Acid
- Hydrochloric Acid
- Phosphoric Acid
- Sea Water



Visit our website, www.cranecpe.com, to view these and other lined products, applications, brochures, certification, documents and more.

XOMOX®

Crane ChemPharma & Energy
Crane Process Flow Technologies GmbH
Heerdter Lohweg 63-71
40549 Düsseldorf, Germany
Phone: +49 211 5956 0
Fax: +49 211 5956 111
www.cranecpe.com

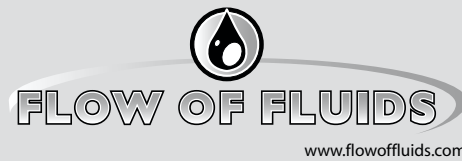

brands you trust.



Crane Co., and its subsidiaries cannot accept responsibility for possible errors in catalogues, brochures, other printed materials, and website information. Crane Co. reserves the right to alter its products without notice, including products already on order provided that such alteration can be made without changes being necessary in specifications already agreed. All trademarks in this material are property of the Crane Co. or its subsidiaries. The Crane and Crane brands logotype, in alphabetical order, (ALOYCO®, CENTER LINE®, COMPAC-NOZ®, CRANE®, DEPA®, DUO-CHEK®, ELRO®, FLOWSEAL®, JENKINS®, KROMBACH®, NOZ-CHEK®, PACIFIC VALVES®, RESISTOFLEX®, REVO®, SAUNDERS®, STOCKHAM®, TRIANGLE®, UNI-CHEK®, WTA®, and XOMOX®) are registered trademarks of Crane Co. All rights reserved.