

XOMOX[®]

brands you trust.



Tuflin[®] High Performance Butterfly Valves

CRANE[®]

ChemPharma Flow Solutions

www.cranepharmaceutical.com

Contents	Page
Unique and patented features	2
Patented soft seat	4
Fire tested and high temperature seats	6
Special application configurations and actuation options	8
Body styles	9
Valve dimensions, bare stem	10
Valve dimensions, manual actuators, soft seated ..	11
Valve dimensions, manual actuators, fire-tested ..	12
Actuator mounting dimensions ..	13
High Performance Butterfly Valve specifications	14
Cv factors	15
Pressure/temperature ratings	16
Break-away torques	18
Valve components	20
Materials of construction	21
How to specify	22
CRANE ChemPharma, Xomox & Matryx actuators	23
CRANE ChemPharma, Xomox Service Centers	23

Appropriate Applications:

- Chemical Processing
- Pulp & Paper
- Air Separation
- Oxygen
- Seawater
- HVAC
- Steam

Versatile valving.

- 1 For superior sealing over prolonged periods, this patented seat is a proven performer. Choose soft-seated, fire-tested or high-temperature designs.
- 2 Tapered, staked pins prevent loosening but permit easy replacement.
- 3 This positive internal over-travel stop protects both the seat and disc.
- 4 For longer wear under difficult conditions, the unique retainer design protects the seat from erosion and abrasion.
- 5 In addition to durable, standard V-ring packing, customers can also choose from optional graphite high-temperature packing or emissions control design.
- 6 Crush-resistant bearings are positioned for superior shaft stability.
- 7 The captured retainer ring is overlapped by the gasket to prevent external leakage at the flange.
- 8 The screwless retainer ring eliminates potential leak paths and simplifies maintenance. (Standard for sizes 2 through 12. Optional on other sizes.)
- 9 Eccentric disc mounting minimizes seat wear and lowers operating torques.



Bearings are uniquely designed and positioned for extended service life.

Bonded to the interior of the stainless steel bearing is PTFE, impregnated with woven fiberglass.

- This unique design resists crushing better than conventional fiberglass backed bearings.
- The stainless steel provides superior shaft support while also permitting reduced bearing thickness. This improves sealing by reducing lateral shaft movement.
- The PTFE's high lubricity facilitates smoother cycling.
- The woven fiberglass reinforces and stabilizes the PTFE, preventing cold-flow.

For high temperature applications, electroless nickel coated stainless steel bearings are also available.

Enhanced durability and emissions control.

There are three bearings. For enhanced durability, two of the shaft bearings are positioned close to the disc (above and below). Bending stresses in the shaft are reduced; Shaft and disc deflection are minimized.

The third bearing is located high on the shaft near the packing chamber. This provides greater shaft stability, assures longer packing life, and helps control emissions.

Tufline® High Performance Butterfly Valves provide superior performance in the most demanding applications.

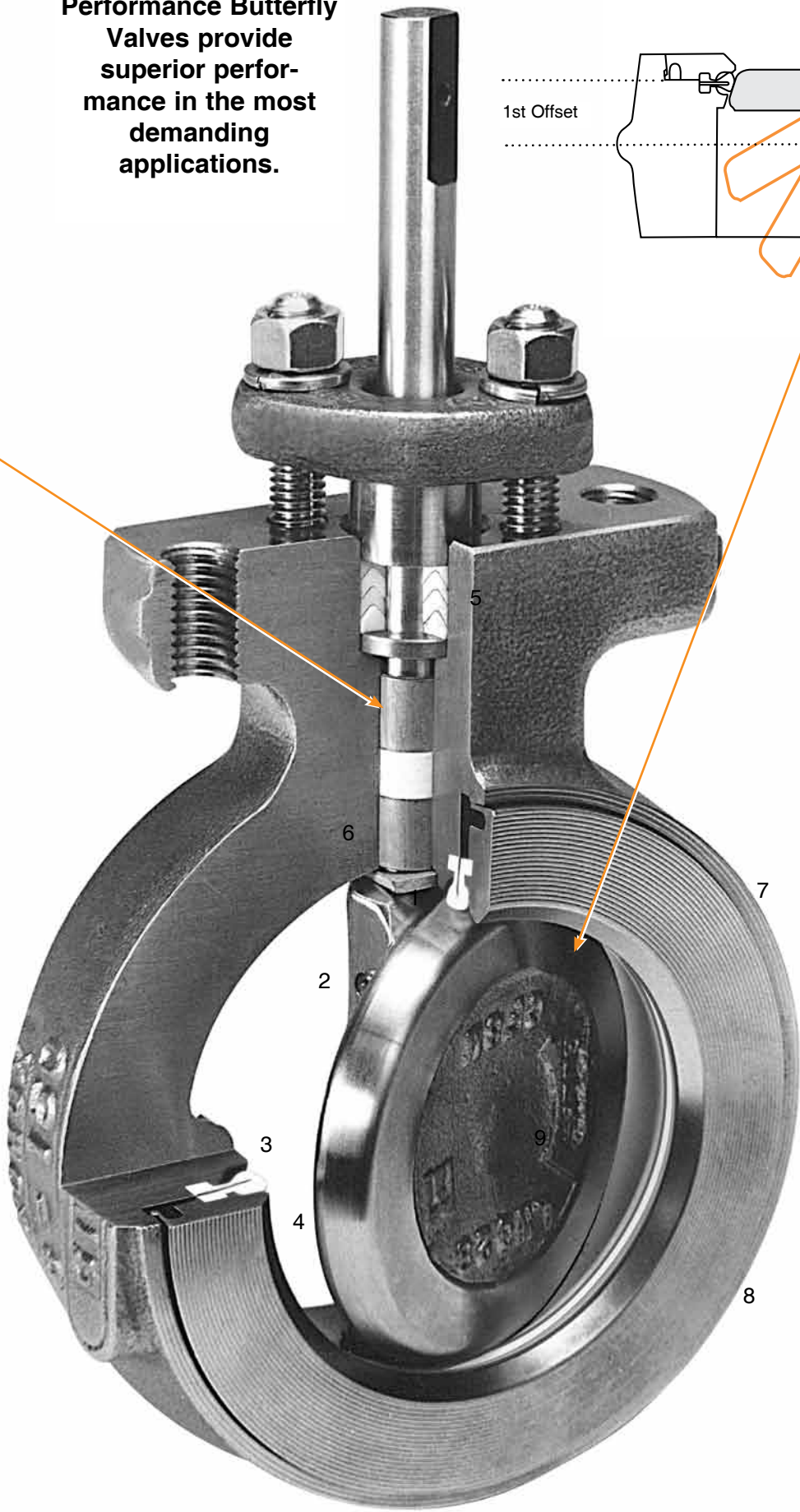
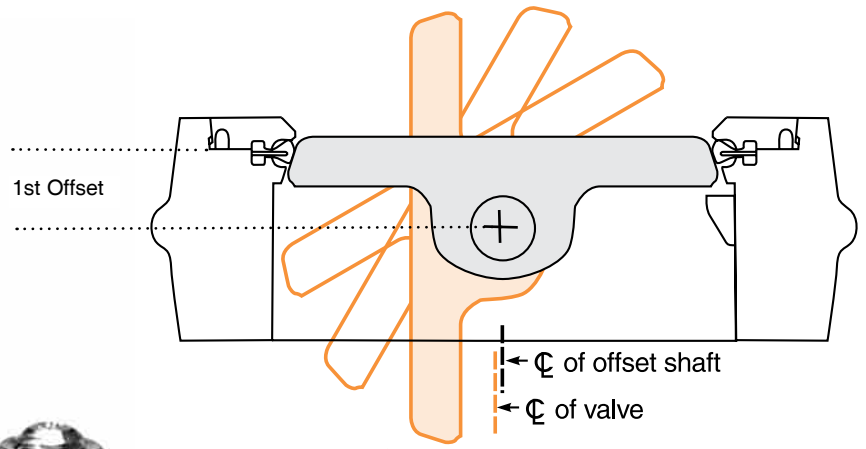

Double offset and eccentric disc mounting extends seat life, reducing maintenance costs and downtime.

Seats last longer and maintenance is reduced because the eccentrically mounted disc minimizes seat deformation and wear.

Reduced seat deformation.

In the open position the disc is not in contact with the seat, so seat deformation cannot occur.

Reduced seat wear.

When the Tufline valve is opened, the eccentrically mounted disc moves with a cam-like action. The disc is lifted away from the seat.

The service life of the seat is greatly extended because moving contact between the disc and seat is virtually eliminated.

Reduced friction also means that operating torque requirements are reduced. This allows the use of smaller, more economical actuators.

360° sealing for sure shutoff.

Because the disc is offset, the shaft is behind the sealing surface of the disc.

When the valve is closed, there is an uninterrupted 360° seal around the full circumference of the disc.

Superior sealing and extended service life.

The seat is axially pliant.

Unlike other seals, there is no radial stretch.

When the valve opens, the seat flexes axially, returning to its original compact shape.

It does not “relax” into the flow path.

This seat design includes two components:

- An outer segment of chemically inert glass reinforced PTFE.
- A deformation-resistant, memory-core membrane.

Simply superior.

This seat is simple. There are no springs to break, no O-rings to swell, and no metal hoops to corrode. Installation is also simple and mistake-proof. Choose soft-seated, fire-tested, or high-temperature designs.

The retainer eclipses the seat, protecting it from erosion and abrasion.

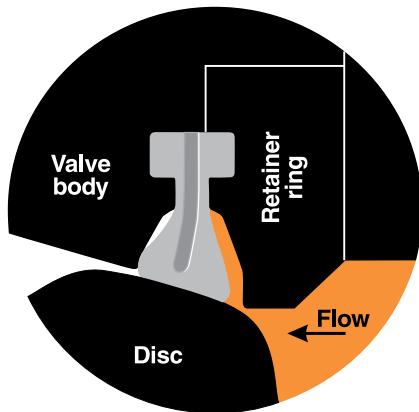
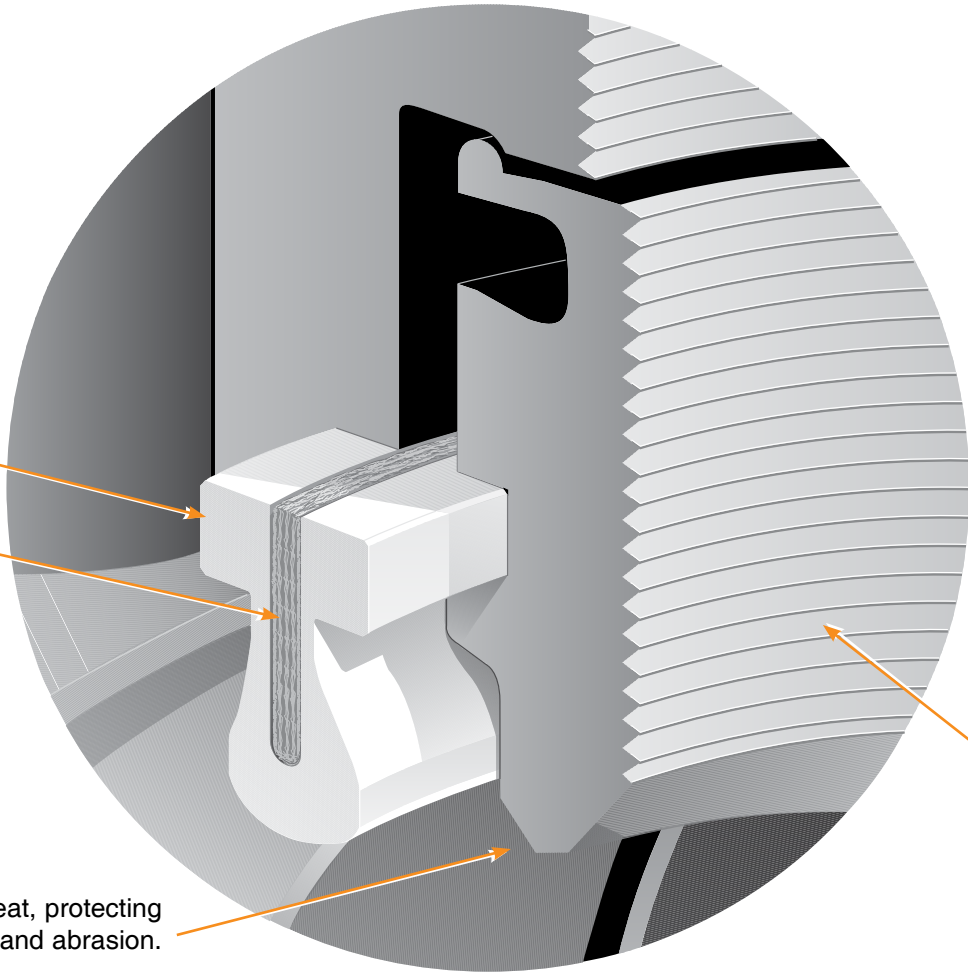

Figure 1.
Valves closed,
with right to left flow.

The axial movement of the seat in the direction of the flow produces a simple, leak-tight seal. It is pressure-assisted. As line pressure increases, the seal tightens. From vacuum through high pressure, tight shutoff is maintained.

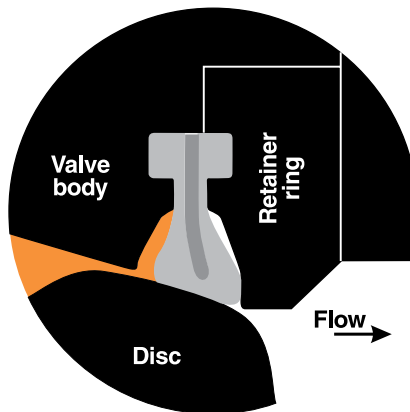

Figure 2.
Valve closed,
with left to right flow.

Bi-directional flow and shutoff are easily accommodated. The same, simple, axial movement of the seat assures a reliable seal in either direction.

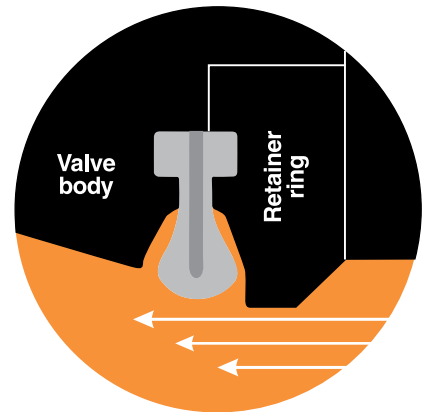
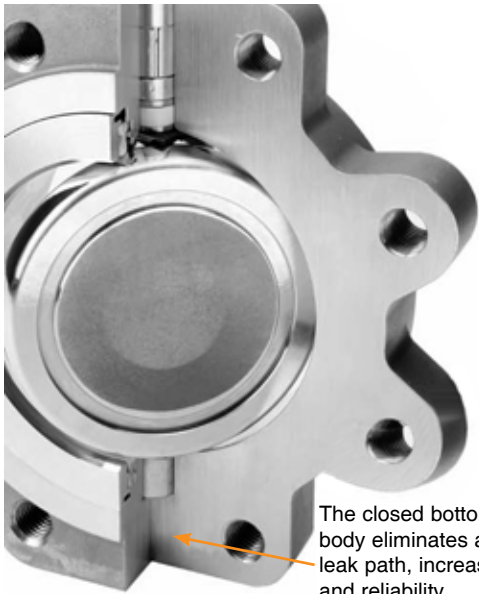

Figure 3.
Valve open, with media flowing.

Even after 100,000 cycles the seat maintains a tight seal. The seat’s internal pliant membrane is the “memory core” that precludes radial deformation.

To further extend seat life, the inside diameter of the retainer ring is smaller than that of the PTFE seat. This protects the seat from erosion and abrasion.



The closed bottom of the valve body eliminates a potential leak path, increasing safety and reliability.



An internal stop protects against seat damage from disc over-travel.

To protect the seat in a butterfly valve, the positive internal stop limits over-travel. An improperly adjusted actuator could force the disc beyond the closed position. This can damage both the seat and disc of a conventional valve that has no travel-stop.

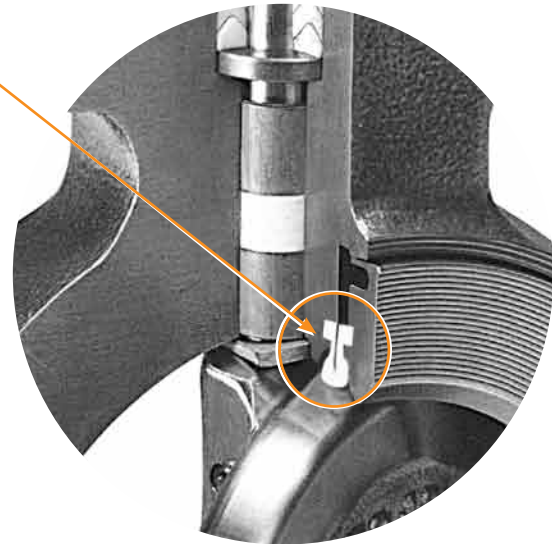

For enhanced emissions control, the patented* snap-in retainer ring is captive.

When the valve is installed in the pipeline, the flange gasket overlaps the captive retainer. This enhances the seal by preventing external leakage at the flange.

There are no screws through the standard butterfly valve retainer ring. Sealing is thereby further improved because potential leak paths are eliminated. Also, there is no bottom plug.



The shaft and disc are securely pinned for more efficient operation and ease of maintenance.

During factory assembly, two stainless steel pins mechanically lock the disc and shaft. This eliminates lost motion and provides better control.

The pins are staked to prevent loosening. They pass through the disc and shaft behind the sealing surface.

The tapered sleeves and tapered pins make replacement of the disc or shaft economical because they do not require matched drilling.

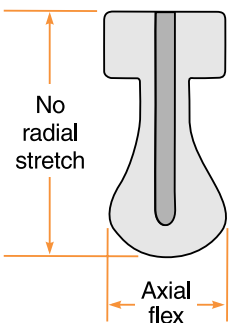

Greatly improved service life is assured because the seat is axially-pliant and resists radial-stretch.

The snap-in retainer ring speeds up maintenance and reduces downtime.

* U.S. Patent No. 4,813,650.

Blow-out Proof Shaft

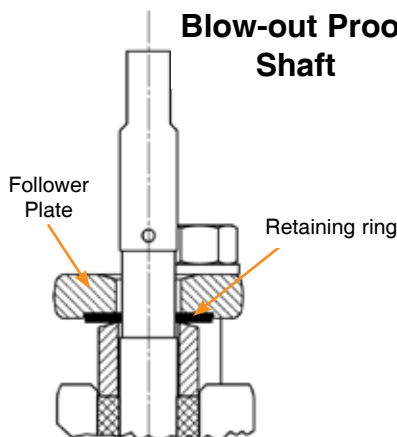

Soft-seat sealing with fire-tested safety.

For applications involving flammable media, the dual component seat offers both superior sealing and fire-tested security.

Proven Performance.

Numerous test results demonstrate this valve's ability to meet or exceed the requirements of API-607 Fourth Edition as well as BS SPEC 6755 Part 2.

The seat combines PTFE and metal sealing elements. The metal component is available in a variety of different alloys.

This seat establishes both a PTFE-to-metal seal and a dual metal-to-metal seal.

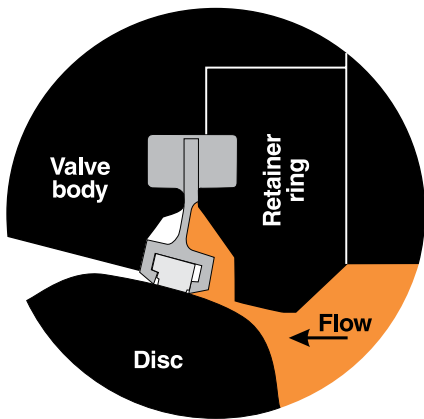
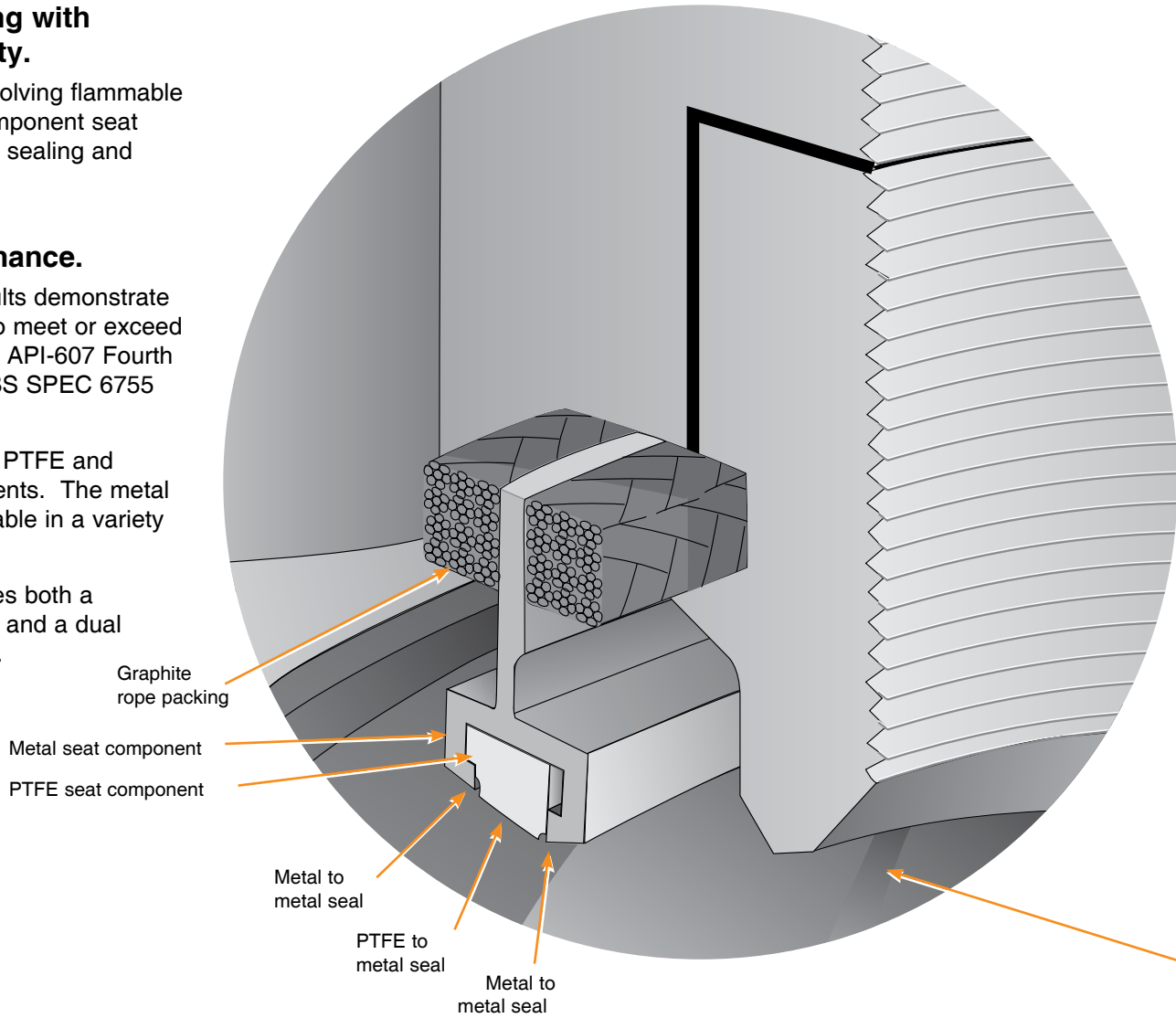

Normal operation - right to left flow.

This unique seat is designed for bi-directional flow control. As pressure increases, the seat shifts axially in the direction of the flow. This tightens the seat contact with the disc for sure sealing.

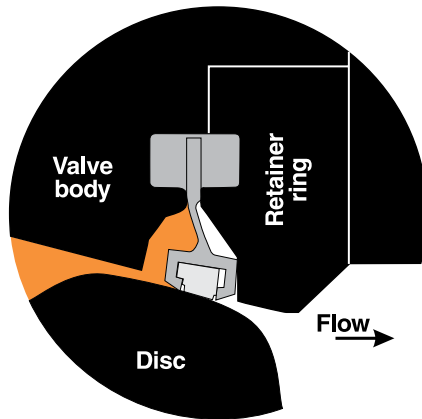

Normal operation - left to right flow.

Both the metal seat and the PTFE seat are in tight contact with the disc. As line pressure increases, the seal tightens, axially.

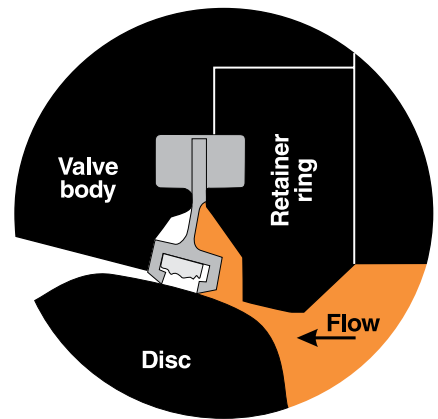

Fire emergency.

In a fire emergency, as the PTFE portion of the seat deteriorates, the metal portion of the seat maintains the integrity of the seal. There is no interruption of the seal.

This also illustrates how the all-metal seat seals.

In case of fire - continuous sealing.

In case of fire, the metal-to-metal seal is uninterrupted. In case of a partial burn, where the PTFE does not completely deteriorate, the metal-to-metal seal continues without interruption.

With many other valves, the seal is temporarily lost during the early, critical stages of a fire.

In the Tufline valve, whether the PTFE is partially or completely destroyed, the seal is maintained.

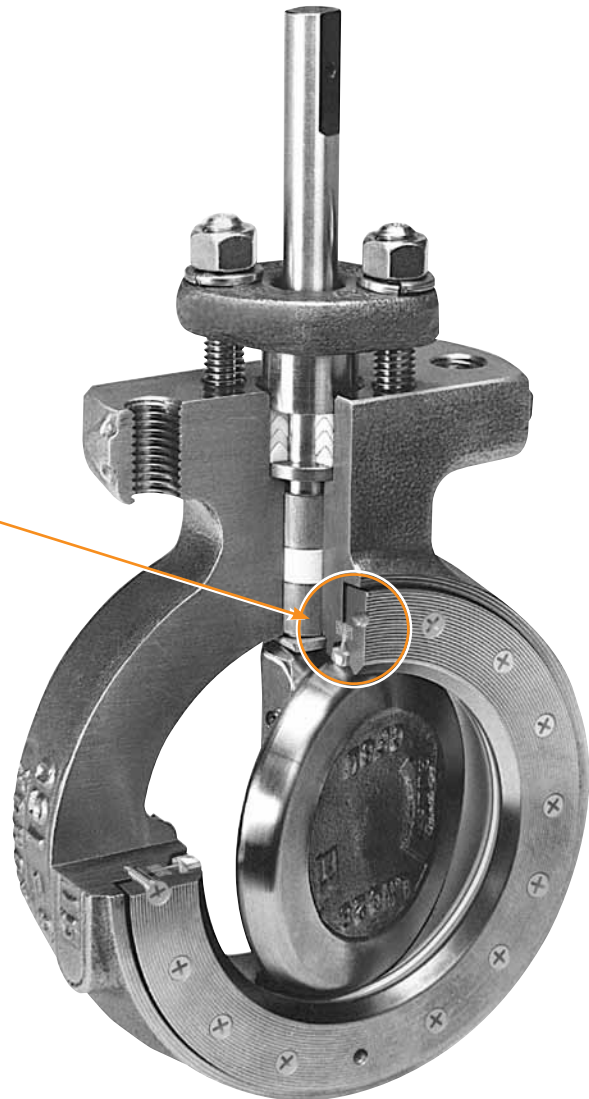

High temperature sealing.



The fire-tested seat with XeniTh insert (FT20) provides bidirectional sealing when operating temperatures do not exceed 600°F.

The tested leak rate of these seats is zero.



Two-point, pressure-assisted sealing in the all-metal seat operates up to 1000°F.

Pressure assisted sealing.

Like the membrane seat, these seats are axially pliant. In the closed position, flow in either direction tightens the seat against the disc.

An adaptable design for specialized service.

This is an extremely versatile valve. Choose from options and reconfigurations that meet specific application requirements.

In each case, the valve maintains the superior sealing characteristics and long-term economy of the standard Tufline design.

Vacuum service.

Standard valves can be used to 25 mm mercury (Hg). Special cleaning, to minimize outgassing, is required for service to 1×10^{-6} mm of mercury.

Steam.

Standard valves with reinforced PTFE (ST2) seats can be used in saturated steam applications up to 135 psia and 350° F.

XeniTh high-temp (ST20 & FT20) seats can be used for saturated and super-heated steam applications up to 600° F.

Valves with CF8M stainless steel bodies are recommended for use in steam applications.

Oxygen and chlorine.

Valves designated for oxygen or chlorine service are thoroughly cleaned and dried per Tufline oxygen and chlorine cleaning standards. After they are tested, valves are packaged and sealed in plastic containers.

NACE trim.

Valves are available to meet the latest NACE specifications for materials used in sour environments: NACE MR0175 / ISO 15156 and NACE MR0103-2003. This valve performs well in applications such as sour gas, sour oil, or other medias that can cause sulfide stress cracking or chloride stress cracking.

Steam jacketed and internally steam traced (STJ Option).

For processing solidifying or agglomerating media, the Tufline STJ offers a patented 3-point heating system. The design includes an integral, full body steam jacket, a steam traced shaft, and steam tracing of the full circumference of the disc.



XeniTh "ST" and "FT" HPBV's are available in ASME Class150 and 300 design sizes 2" thru 24". Lug and wafer designs in wide variety of Body and disc materials are available. Operating Temperatures up to 600°F.

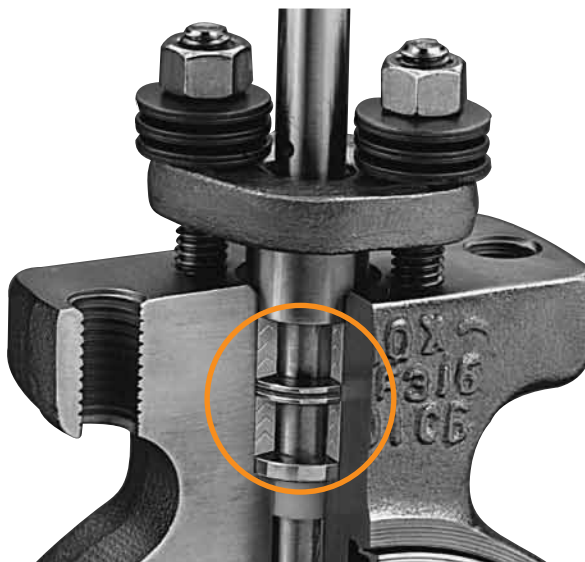

Fugitive emissions control.

The Tufline emissions control valve is available with an auxiliary live-loaded packing option.

There are two full sets of packing separated by a lantern ring. Also available is an optional leak-off port (XP option).



Cryogenic.

Both full and semi-cryogenic models are available. The bodies are stainless steel. The seats are a combination of stainless steel and Kel-F. Axially pliant sealing assures tight shutoff. See Xomox Bulletin 333767 for additional information.



Rail tank car.

This bottom-mounted, bottom-operated Tuflin valve is available with a steam jacketed body and a steam traced shaft and disc, as well as a stainless steel body

Body styles to meet your needs.

This Tuflin valve is available in three different body styles and a variety of seat materials.

Wafer Style.

Figure numbers 801, 803, and 806. The snap-in seat retainer ring provides a full 100% gasket sealing width.



Lug Style with snap-in retainer.

Uni-directional dead end service.

Figure numbers 811, 813, and 816. Designated for full pressure dead end service with the seat retainer ring located against the upstream flange. The snap-in seat retainer ring provides a full 100% gasket sealing width.

Lug Style with bolted retainer.

Bi-directional dead end service.

Figure numbers 821 and 823. Designated for full pressure dead end service with the seat retainer ring located either against the upstream flange or exposed downstream.

The screw-affixed seat retainer ring provides a minimum 65% gasket sealing width, as specified by API 609.

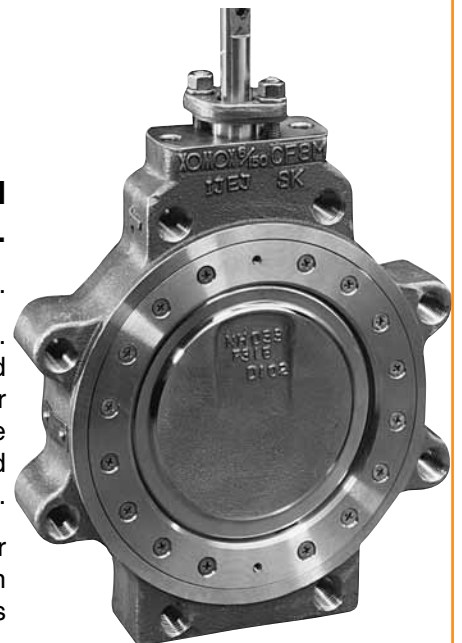

Dimensions Bare Stem

See page 13 for actuator mounting dimensions.

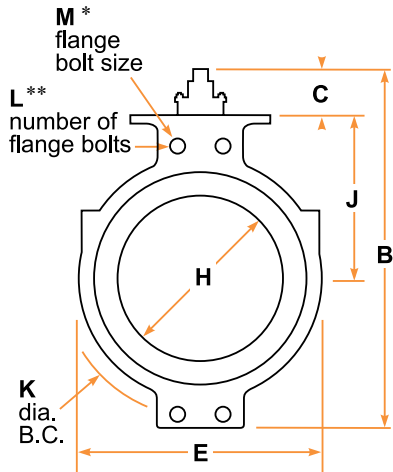

*Alignment hole allows clearance for specified bolt size.
 **Defines number of flange bolts required. Number of alignment holes varies by size and pressure class.

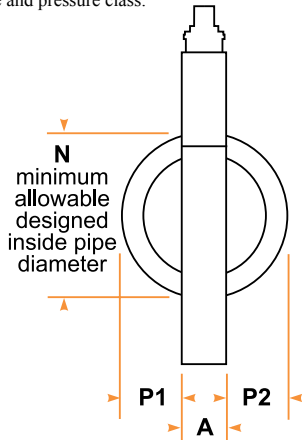

Class 150 / 285△P

Size	A	Wafer ^B	Lug	C	Wafer ^E	Lug	H	J	K	L	M	N	P1	P2
2	1.75	8.74	8.76	3.25	4.00	4.62	2.19	3.38	4.75	4	5/8-11	1.94	.11	.49
3	1.88	10.00	10.33	3.25	5.38	6.00	3.13	4.00	6.00	4	5/8-11	2.90	.68	.69
4	2.12	11.51	12.10	3.25	6.75	8.63	4.02	4.88	7.50	8	5/8-11	3.83	1.01	1.01
5	2.25	12.61	13.16	3.25	7.62	9.75	4.81	5.38	8.50	8	3/4-10	4.81	1.33	1.39
6	2.25	13.75	14.28	3.25	8.62	10.74	5.77	6.00	9.50	8	3/4-10	5.77	1.72	1.91
8	2.50	16.06	16.56	3.25	10.88	13.13	7.45	7.12	11.75	8	3/4-10	7.62	2.44	2.64
10	2.81	19.25	20.28	3.50	12.98	16.00	9.27	9.00	14.25	12	7/8-9	9.56	3.14	3.46
12	3.19	21.25	22.53	3.50	15.23	18.76	11.05	10.00	17.00	12	7/8-9	11.38	3.80	4.22
14	3.62	25.68	26.11	3.50	16.25	20.99	12.59	11.62	18.75	12	1-8	13.13	4.37	4.69
16	4.00	29.18	29.18	3.50	18.50	23.50	14.43	13.12	21.25	16	1-8	15.00	5.10	5.45
18	4.50	31.12	31.12	3.50	21.00	25.25	16.30	14.12	22.75	16	1 1/8-8	16.88	5.73	6.35
20	5.00	36.56	36.56	5.75	23.07	27.50	18.15	15.50	25.00	20	1 1/8-8	18.81	6.41	7.03
24	6.06	41.06	41.06	5.75	27.25	32.25	21.59	17.75	29.50	20	1 1/4-8	22.63	7.45	8.26

Class 300 / 740△P

Size	A	Wafer ^B	Lug	C	Wafer ^E	Lug	H	J	K	L	M	N	P1	P2
3	1.87	11.38	11.63	3.25	5.15	8.13	3.13	4.63	6.62	8	3/4-10	2.90	.64	.77
4	2.12	13.47	13.69	3.25	6.35	9.38	4.02	5.75	7.88	8	3/4-10	3.83	.97	1.09
6	2.31	16.03	16.24	3.25	8.67	12.12	5.77	7.00	10.62	12	3/4-10	5.77	1.79	1.80
8	2.87	18.62	18.89	3.50	10.87	14.76	7.45	8.25	13.00	12	7/8-9	7.63	2.20	2.54
10	3.25	23.04	22.04	3.50	12.97	17.25	9.27	9.56	15.25	16	1-8	9.56	2.96	3.23
12	3.62	25.68	25.68	3.50	15.27	19.98	11.05	11.00	17.75	16	1 1/8-8	11.38	3.72	3.90
14	4.50	31.87	31.87	5.75	16.25	22.49	12.59	13.62	20.25	20	1 1/8-8	12.50	4.05	4.17
16	5.25	33.69	33.69	5.75	18.50	25.00	14.43	14.75	22.50	20	1 1/4-8	14.31	4.62	4.75
18	5.75	36.43	36.43	5.75	21.00	27.25	16.30	15.75	24.75	24	1 1/4-8	16.13	5.30	5.43
20	6.12	38.38	38.38	5.75	23.00	29.49	18.15	17.00	27.00	24	1 1/4-8	17.94	6.04	6.17
24	7.00	43.56	43.56	5.75	27.25	35.00	21.59	19.50	32.00	24	1 1/2-8	21.56	7.35	7.47

Class 600 / 1480△P

Size	A	Wafer ^B	Lug	C	Wafer ^E	Lug	H	J	K	L	M	N	P1	P2
3	2.25	13.31	13.31	3.25	5.31	8.12	3.13	5.25	6.62	8	3/4-10	2.90	.64	.81
4	2.50	14.81	14.81	3.25	6.62	10.25	4.02	6.12	8.50	8	7/8-9	3.83	1.03	1.43
6	3.06	19.06	19.06	3.25	8.50	13.49	5.77	8.12	11.50	12	1-8	5.77	1.58	1.72
8	4.00	21.69	21.69	3.50	10.62	15.99	7.45	9.50	13.75	12	1 1/8-8	7.44	1.94	2.06
10	4.62	28.19	28.19	5.75	15.07	19.50	9.27	11.88	17.00	16	1 1/4-8	9.31	2.76	2.76
12	5.50	30.93	30.93	5.75	16.25	21.75	11.05	13.12	19.25	20	1 1/4-8	11.06	3.24	3.36
14	6.12	34.00	34.00	5.75	16.25	23.75	12.59	14.25	20.75	20	1 3/8-8	12.12	3.20	3.53
16	7.00	37.25	37.25	5.75	26.71	26.71	13.70	15.75	23.75	20	1 1/2-8	13.80	3.53	3.75
18	7.25	38.75	38.75	5.75	21.00	28.75	15.68	16.75	25.75	20	1 5/8-8	15.25	4.28	4.61
20	8.50	46.37	46.37	7.50	23.00	31.75	17.75	18.12	28.50	24	1 5/8-8	17.00	4.65	4.98
24	9.13	50.50	50.50	7.50	30.75	39.50	18.96	21.00	33.00	24	1 7/8-8	18.00	4.65	6.10

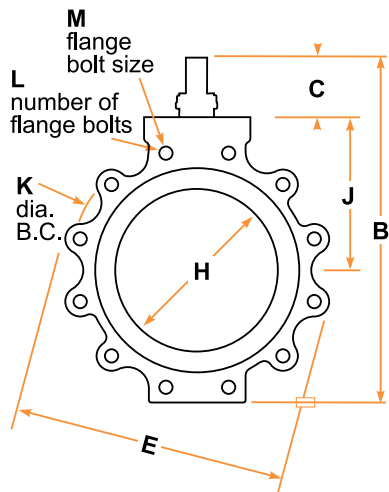

For information on 30" - 48" Tuffline High Performance Butterfly Valves, see Xomox Brochure 335251.

Dimensions - Manual Actuators

For soft (ST) seated valves. Valve weights are in pounds.

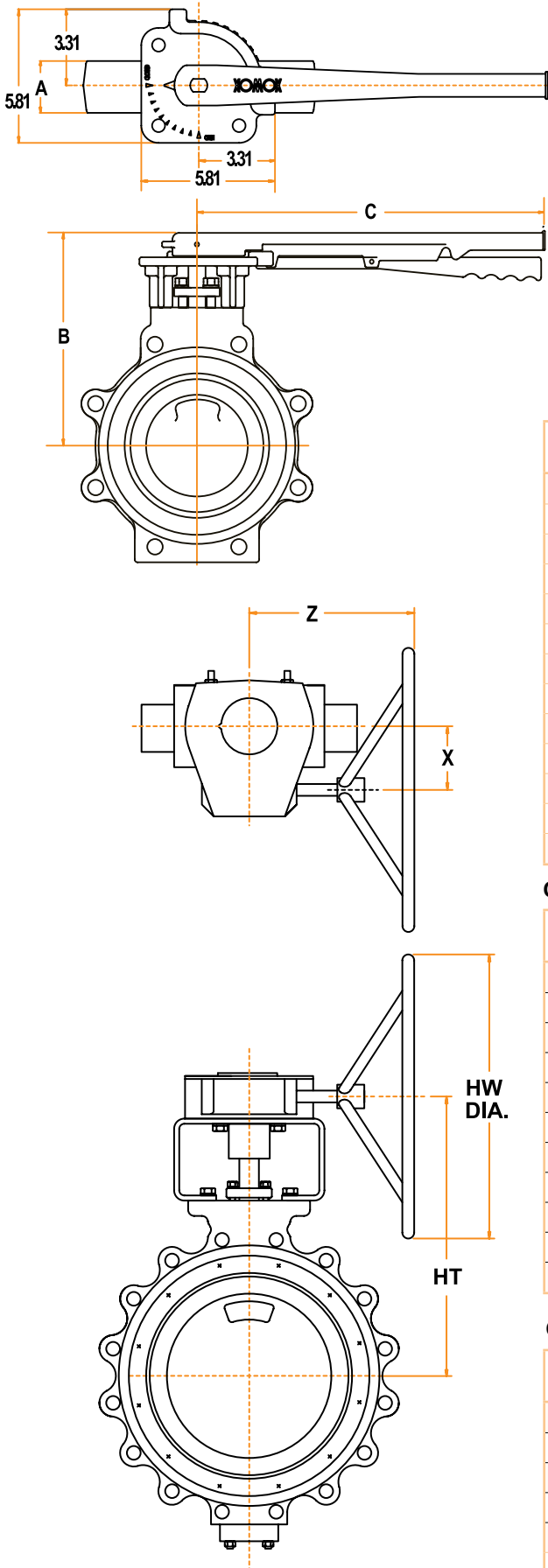

Class 150 Lever

Size	A	B	C	WT (wafer)	WT (lug)
2	1.75	6.69	14	15	19
3	1.88	7.31	14	18	23
4	2.12	8.19	14	27	33
5	2.25	8.69	17	32	39
6	2.25	9.31	17	38	45
8	2.50	10.44	17	56	69

Class 300 Lever

Size	A	B	C	WT (wafer)	WT (lug)
3	1.88	7.94	14	20	28
4	2.12	9.06	17	30	42
6	2.31	10.31	17	41	60

Class 150 Gear

Size	HT	HW	X	Z	WT (wafer)	WT (lug)
2	6.75	8	1.83	5.00	13	16
3	7.38	8	1.83	5.00	16	20
4	8.25	8	1.83	5.00	25	30
5	8.75	8	1.83	5.00	29	35
6	9.38	8	1.83	5.00	35	41
8	10.50	8	2.36	6.00	55	68
10	12.75	8	2.36	6.00	84	97
12	13.94	12	3.00	9.75	123	154
14	18.87	18	3.38	11.69	216	281
16	20.37	24	3.38	14.37	277	389
18	21.49	24	4.38	13.25	359	496
20	25.37	24	4.38	13.25	526	613
24	28.35	24	2.36	20.10	833	990

Class 300 Gear

Size	HT	HW	X	Z	WT (wafer)	WT (lug)
3	8.00	8	1.83	5.00	18	25
4	9.12	8	1.83	5.00	27	38
6	10.38	8	2.36	6.00	40	58
8	12.19	12	3.00	9.75	66	98
10	13.75	18	4.38	11.69	154	208
12	14.88	30	5.38	13.88	210	314
14	23.49	30	5.38	15.44	344	555
16	25.34	24	2.36	20.10	615	807
18	25.59	24	2.10	20.10	729	943
20	24.59	30	6.10	21.53	839	1,004
24	27.05	24	7.13	23.92	1,275	1,844

Class 600 Gear

Size	HT	HW	X	Z	WT (wafer)	WT (lug)
3	11.42	8	1.83	5.00	45	49
4	13.04	8	2.36	6.00	64	69
6	14.94	12	3.00	9.75	130	138
8	16.84	18	4.38	11.69	300	308
10	21.75	30	5.38	15.44	500	510
12	23.71	24	2.36	20.10	753	765

Dimensions - Manual Actuators

For fire tested (FT) and high temperature (HT) seated valves. Valve weights are in pounds.

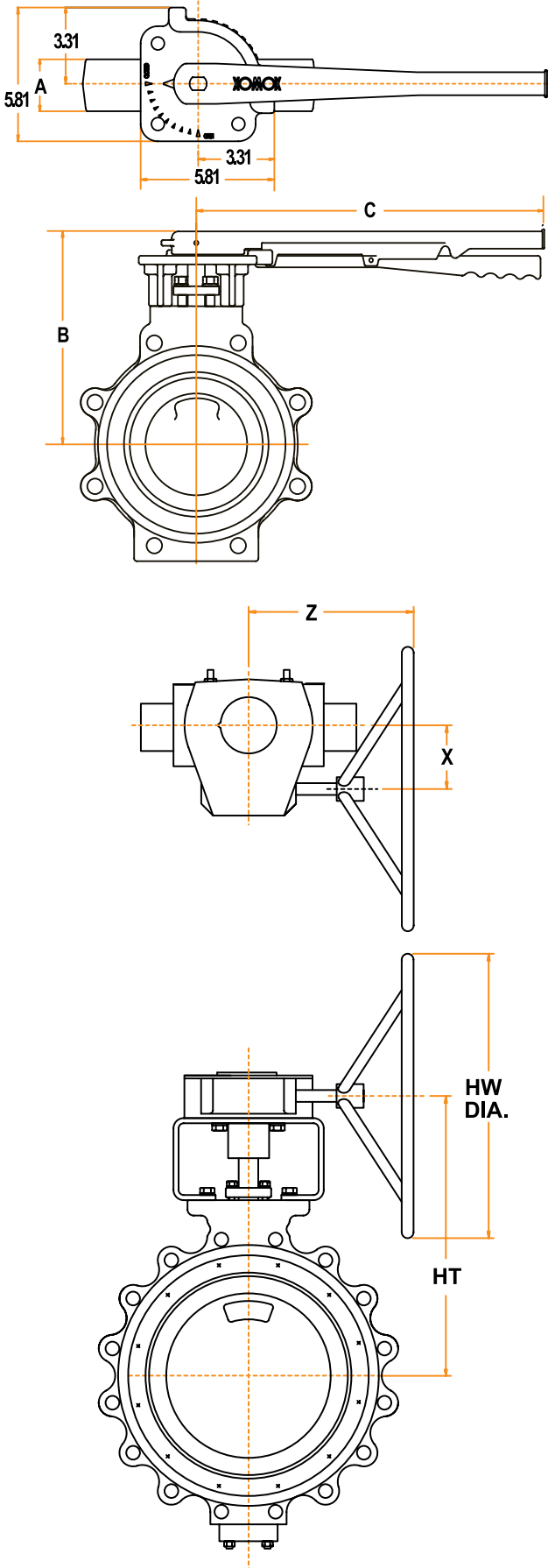

Class 150 Lever

Size	A	B	C	WT (wafer)	WT (lug)
2	1.75	6.69	14	15	19
3	1.88	7.31	14	18	23
4	2.12	8.19	14	27	33
5	2.25	8.69	17	32	39
6	2.25	9.31	17	38	45

Class 300 Lever

Size	A	B	C	WT (wafer)	WT (lug)
3	1.88	7.94	14	20	28
4	2.12	9.06	17	30	42

Class 150 Gear

Size	HT	HW	X	Z	WT (wafer)	WT (lug)
2	7.00	10	2.06	7.50	44	47
3	7.63	10	2.06	7.50	47	51
4	8.51	10	2.06	7.50	56	61
5	9.13	10	2.06	7.50	61	67
6	9.51	10	2.06	7.50	67	73
8	11.12	14	2.63	9.50	98	110
10	13.38	14	2.63	9.50	127	140
12	14.62	18	3.53	11.13	191	221
14	19.09	24	3.53	12.25	217	282
16	20.59	30	4.84	15.88	312	424
18	22.21	24	2.36	20.10	453	590
20	25.37	18	2.10	18.76	618	705
24	28.39	30	2.10	21.51	842	999

Class 300 Gear

Size	HT	HW	X	Z	WT (wafer)	WT (lug)
3	8.25	10	2.06	7.50	31	38
4	9.38	10	2.06	7.50	40	51
6	10.88	14	2.63	9.50	63	81
8	12.89	18	3.53	11.13	96	128
10	14.00	24	3.53	12.25	142	196
12	15.13	30	4.84	15.88	212	316
14	24.22	30	2.36	21.51	426	637
16	22.30	24	3.80	22.53	700	892
18	23.30	24	3.80	24.11	823	1,052
20	24.75	24	9.33	23.40	1,088	1,253
24	27.25	30	9.33	24.90	1,457	2,026

Class 600 Gear

Size	HT	HW	X	Z	WT (wafer)	WT (lug)
3	11.54	10	2.36	8.94	61	65
4	13.53	12	2.63	9.19	87	92
6	15.12	18	3.38	11.69	180	188
8	16.87	24	4.38	13.25	300	310
10	22.47	24	2.36	20.10	573	583
12	23.71	24	2.36	20.10	753	765

Actuator Mounting Pad Dimensions

These dimensions apply for both wafer and lug style valves.

All dimensions are common to soft-seated, fire tested, and high-temperature valves.

Class 150 / 285 Δ P

Sizes 3" to 8" ASME Class 150
 Sizes 3" to 6" ASME Class 300

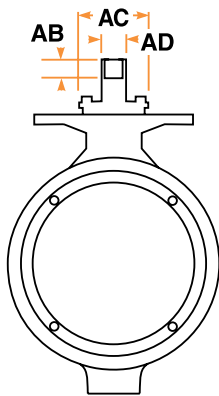
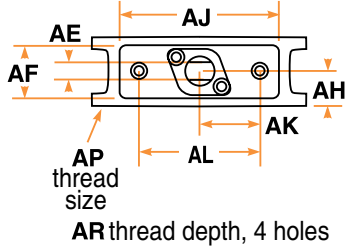

Valve Size	AB	AC	AD	AE	AF	AH	AJ	AK	AL	AM	AN	AP	AR
3	1.00	1.98	0.50	0.37	1.70	0.91	4.00	1.56	3.12	-	-	1/2-13	0.75
4	1.00	1.93	0.62	0.44	1.94	1.03	4.00	1.56	3.12	-	-	1/2-13	0.75
5	1.00	1.98	0.75	0.56	2.00	1.15	4.00	1.56	3.12	-	-	1/2-13	0.75
6	1.00	1.98	0.75	0.56	2.00	1.19	4.00	1.56	3.12	-	-	1/2-13	0.75
8	1.00	2.32	1.00	0.69	2.25	1.31	4.00	1.56	3.12	-	-	1/2-13	0.75
10	1.00	2.44	1.25	0.81	2.44	1.53	6.25	2.50	5.00	0.75	1.50	1/2-13	0.75
12	1.50	3.45	1.50	1.00	2.62	1.76	6.25	2.50	5.00	0.75	1.50	1/2-13	0.75
14	1.50	3.88	1.50	1.00	2.81	1.66	9.50	4.00	8.00	0.75	1.50	5/8-11	Thru
16	1.50	4.00	1.75	1.12	2.85	1.83	9.50	4.00	8.00	0.75	1.50	5/8-11	Thru
18	1.50	4.00	1.75	1.12	2.85	2.00	9.50	4.00	8.00	0.75	1.50	5/8-11	Thru
20	2.00	5.50	2.00	1.50	3.62	2.19	15.00	6.50	13.00	1.00	2.00	1-8	Thru
24	2.50	6.00	2.50	1.75	4.00	2.62	15.00	6.50	13.00	1.00	2.00	1-8	Thru

Class 300 / 740 Δ P

Sizes 3" to 12" ASME Class 600
 Sizes 8" and larger ASME Class 300
 Sizes 10" and Larger ASME Class 150

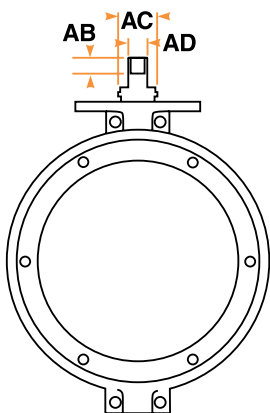
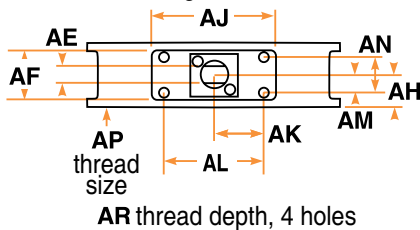

Valve Size	AB	AC	AD	AE	AF	AH	AJ	AK	AL	AM	AN	AP	AR
3	1.00	2.38	0.62	0.44	1.69	0.91	4.00	1.56	3.12	-	-	1/2-13	0.88
4	1.00	2.75	0.75	0.56	1.95	1.03	4.00	1.56	3.12	-	-	1/2-13	0.88
6	1.00	2.75	1.00	0.69	2.13	1.19	4.00	1.56	3.12	-	-	1/2-13	0.88
8	1.00	3.25	1.25	0.81	2.50	1.31	6.25	2.50	5.00	0.75	1.50	1/2-13	0.88
10	1.50	3.88	1.50	1.00	2.88	1.53	6.25	2.50	5.00	0.75	1.50	1/2-13	0.88
12	1.50	4.00	1.75	1.12	3.31	1.65	6.25	2.50	5.00	0.75	1.50	1/2-13	0.88
14	2.00	5.50	2.00	1.50	3.75	2.19	16.00	6.50	13.00	1.00	2.00	1-8	Thru
16	2.50	6.00	2.50	1.75	4.25	2.56	16.00	6.50	13.00	1.00	2.00	1-8	Thru
18	2.50	6.00	2.50	1.75	4.25	2.81	16.00	6.50	13.00	1.00	2.00	1-8	Thru
20	2.50	6.25	3.00	2.00	6.12	3.00	18.00	7.50	15.00	1.50	3.00	1-8	Thru
24	2.50	7.50	3.50	2.25	7.00	3.44	18.00	7.50	15.00	1.50	3.00	1-8	Thru

Class 600 / 1480 Δ P

Valve Size	AB	AC	AD	AE	AF	AH	AJ	AK	AL	AM	AN	AP	AR
3	1.00	2.75	0.75	0.56	2.25	1.19	6.50	2.50	5.00	0.50	1.00	1/2-13	0.75
4	1.00	2.75	1.00	0.69	2.50	1.33	6.50	2.50	5.00	0.50	1.00	1/2-13	0.75
6	1.00	3.25	1.25	0.81	3.06	1.60	6.50	2.50	5.00	0.50	1.00	1/2-13	0.75
8	1.50	3.88	1.50	1.00	4.00	2.06	9.50	4.00	8.00	0.69	1.38	5/8-11	1.00
10	2.00	5.50	2.00	1.50	4.62	2.12	16.00	6.50	13.00	1.00	2.00	1-8	1.50
12	2.50	6.00	2.50	1.75	5.50	2.81	16.00	6.50	13.00	1.00	2.00	1-8	1.50
14	2.50	6.25	3.00	2.00	6.12	3.19	18.00	7.50	15.00	1.50	3.00	1-8	1.50
16	2.50	7.50	3.50	2.25	6.75	3.38	18.00	7.50	15.00	1.50	3.00	1-8	Thru
18	2.50	7.50	3.50	2.25	7.13	3.75	18.00	7.50	15.00	1.50	3.00	1-8	Thru
20	3.50	8.00	4.00	2.75	8.00	4.38	18.00	7.50	15.00	2.00	4.00	1 1/4-7	1.00
24	3.50	9.00	4.50	3.25	9.13	5.25	18.18	7.50	15.00	1.88	3.75	1 1/4-7	Thru

Tufline High Performance Butterfly Valve Specifications

Typical ST seat specification.

1.0 Scope

This specification covers the design and testing of high pressure offset seat butterfly valves.

2.0 Applicable Standards

The following standards shall apply:

ASME B16.5: Pipe Flanges and Flanged Fittings (24" size and smaller)

ASME B16.34: Valves - Flanged and Buttwelding End

MSS SP-25: Standard Marking System for Valves, Fittings, Flanges, and Unions

MSS SP-61: Pressure Testing of Steel Valves

MSS SP-68: High Pressure - Offset Seat Butterfly Valves

API 598: Valve Inspection and Testing

API 609: Butterfly Valves, Lug-Type and Wafer-Type

PED 97/23 EG: Pressure Equipment Directive Annex II, Module H

3.0 Design Requirements

3.1 Valves shall be High Performance Butterfly with offset seat and eccentric shaft. They shall be capable of sealing against full differential pressure in either flow direction.

3.2 Valve seat shall be both self and pressure energized with an inert, fiberglass core.

The self-energizing Fiberglass member shall be isolated from the line media.

3.3 Valves shall have retained top and bottom low-friction bearings.

3.4 Shaft design shall be single or dual piece.

3.5 Seat retainer rings must be recessed in the body so the flange gasket prevents any potential external leakage.

3.6 Valves shall have internal over-travel stops to prevent the disc from rotating through the seats.

3.7 Valves shall be Tufline or approved equal.

4.0 Materials of Construction

4.1 Valves shall be constructed using new materials and components.

4.2 Carbon steel valves shall be constructed from the following materials:

4.2.1 Body - ASTM A216 Grade WCB

4.2.2 Disc - ASTM A351 Grade CF-8M

4.3 Stainless steel valves shall be constructed from the following materials:

4.3.1 Body - ASTM A351 Grade CF-8M

4.3.2 Disc - ASTM A351 Grade CF-8M

4.4 Shafts shall be ASTM A564 Type 630, H 1075 (17-4PH) SS or 316 SS.

5.0 Inspection and Testing

5.1 Valves shall be hydrostatically shell tested per ASME B16.34 and MSS SP-61.

5.2 Valves shall be seat tested per ASME B16.34 and MSS SP-61. No leakage is permitted for resilient seated valves.

5.3 API 598 testing is available on request.

Sample Figure Number:

6" 801-267-TT-ST2-L

Typical FT seat specification.

1.0 Scope

This specification covers the design and testing of high pressure offset seat butterfly valves.

2.0 Applicable Standards

The following standards shall apply:

ASME B16.5: Pipe Flanges and Flanged Fittings (24" size and smaller)

ASME B16.34: Valves - Flanged and Buttwelding End

MSS SP-25: Standard Marking System for Valves, Fittings, Flanges, and Unions

MSS SP-61: Pressure Testing of Steel Valves

MSS SP-68: High Pressure - Offset Seat Butterfly Valves

API 598: Valve Inspection and Testing

API 607: Fire Test for Soft-Seated Quarter Turn Valves

API 609: Butterfly Valves, Lug-Type and Wafer-Type

PED 97/23 EG: Pressure Equipment Directive Annex II, Module H

3.0 Design Requirements

3.1 Valves shall be High Performance Butterfly with offset seat and eccentric shaft. They shall be capable of sealing against full differential pressure in either flow direction.

3.2 Valve seat shall be both self and pressure energized with two (2) metal sealing points and one (1) PTFE or similar material insert in contact with the disc at all times.

3.3 Valves shall have retained top and bottom low-friction bearings.

3.4 Shaft design shall be single or dual piece.

3.5 Seat retainer rings must be recessed in the body so the flange gasket prevents any potential external leakage.

3.6 Valves shall have internal over-travel stops to prevent the disc from rotating through the seats.

3.7 Valves shall be Tufline or approved equal.

4.0 Materials of Construction

4.1 Valves shall be constructed using new materials and components.

4.2 Carbon steel valves shall be constructed from the following materials:

4.2.1 Body - ASTM A216 Grade WCB

4.2.2 Disc - ASTM A351 Grade CF-8M

4.3 Stainless steel valves shall be constructed from the following materials:

4.3.1 Body - ASTM A351 Grade CF-8M

4.3.2 Disc - ASTM A351 Grade CF-8M

4.4 Shafts shall be ASTM A564 Type 630, H 1075 or H 1150-M (17-4PH) SS.

5.0 Inspection and Testing

5.1 Valves shall be hydrostatically shell tested per ASME B16.34 and MSS SP-61.

5.2 Valves shall be seat tested per ASME B16.34 and MSS SP-61. No leakage is permitted for resilient seated valves.

5.3 API 598 testing is available on request.

5.4 Fire tested valves shall be qualified to API 607, 4TH Edition fire test standard.

Sample Figure Number:

6" 801-267-SG-FT1-G

Typical HT seat specification.

1.0 Scope

This specification covers the design and testing of high pressure offset seat butterfly valves.

2.0 Applicable Standards

The following standards shall apply:

ASME B16.5: Pipe Flanges and Flanged Fittings (24" size and smaller)

ASME B16.34: Valves - Flanged and Buttwelding End

ASME/FCI 70-2: Control Valve Seat Leakage

MSS SP-25: Standard Marking System for Valves, Fittings, Flanges, and Unions

MSS SP-68: High Pressure - Offset Seat Butterfly Valves

API 609: Butterfly Valves, Lug-Type and Wafer-Type

PED 97/23 EG: Pressure Equipment Directive Annex II, Module H

3.0 Design Requirements

3.1 Valves shall be High Performance Butterfly with offset seat and eccentric shaft.

They shall be capable of providing 10% of Class IV shutoff in either flow direction.

3.2 Valve seat shall be both self and pressure energized with two (2) metal sealing points in contact with the disc at all times.

3.3 Valves shall have retained top and bottom low-friction bearings.

3.4 Shaft design shall be single or dual piece.

3.5 Seat retainer rings must be recessed in the body so the flange gasket prevents any potential external leakage.

3.6 Valves shall have internal over-travel stops to prevent the disc from rotating through the seats.

3.7 Valves shall be Tufline or approved equal.

4.0 Materials of Construction

4.1 Valves shall be constructed using new materials and components.

4.2 Carbon steel valves shall be constructed from the following materials:

4.2.1 Body - ASTM A216 Grade WCB

4.2.2 Disc - ASTM A351 Grade CF-8M

4.3 Stainless steel valves shall be constructed from the following materials:

4.3.1 Body - ASTM A351 Grade CF-8M

4.3.2 Disc - ASTM A351 Grade CF-8M

4.4 Shafts shall be ASTM A564 Type 630, H 1075 or H 1150-M (17-4PH) SS.

5.0 Inspection and Testing

5.1 Valves shall be hydrostatically shell tested per ASME B16.34 and MSS SP-61.

5.2 Valves shall be seat tested per ASME/FCI 70-2 to 10% of Class IV.

Sample Figure Number:

6" 801-267-SG-HT1-G

Cv Factors For Valve Sizing & Valve Weights

Cv factors are based on equivalent sized pipe.

Class 150 / 285△P

Disc position - Degrees open

Valve Size	10°	20°	30°	40°	50°	60°	70°	80°	90°
2	4	10	19	29	46	65	94	125	152
3	7	19	37	56	90	127	184	244	296
4	12	33	64	98	157	222	321	425	517
5	19	51	102	154	247	351	507	671	816
6	32	85	166	255	409	581	839	1110	1350
8	55	146	289	439	702	996	1439	1905	2316
10	87	232	459	697	1116	1584	2287	3028	3682
12	125	334	660	1003	1604	2277	3289	4354	5295
14	172	461	910	1383	2213	3141	4537	6006	7303
16	224	599	1182	1797	2875	4082	5895	7805	9490
18	291	778	1536	2335	3735	5302	7658	10138	12328
20	360	962	1900	2888	4621	6559	9473	12542	15250
24	504	1348	2662	4046	6473	9188	13271	17569	21363

Valve weight

Valve Size	Wafer	Lug
2	7	10
3	10	14
4	19	24
5	29	35
6	29	35
8	47	59
10	75	88
12	107	137
14	150	215
16	200	312
18	268	405
20	435	522
24	648	805

Class 300 / 740△P

Disc position - Degrees open

Valve Size	10°	20°	30°	40°	50°	60°	70°	80°	90°
3	6	16	34	50	78	112	161	213	260
4	11	30	62	90	143	204	295	390	475
6	30	78	161	236	372	533	769	1017	1240
8	54	141	292	427	674	965	1392	1841	2245
10	84	222	458	669	1056	1514	2182	2886	3520
12	122	321	663	969	1530	2193	3162	4182	5100
14	142	380	750	1140	1824	2589	3739	4950	6019
16	186	498	984	1496	2394	3398	4907	6497	7900
18	239	639	1261	1917	3067	4353	6288	8324	10122
20	312	835	1649	2506	4009	5691	8220	10882	13232
24	440	1176	2321	3529	5645	8013	11574	15322	18631

Valve weight

Valve Size	Wafer	Lug
3	15	25
4	24	39
6	35	62
8	59	93
10	108	172
12	158	288
14	232	443
16	430	622
18	544	773
20	645	810
24	1005	1574

Class 600 / 1480△P

Disc position - Degrees open

Valve Size	10°	20°	30°	40°	50°	60°	70°	80°	90°
3	4	11	21	33	52	74	107	141	172
4	7	18	35	53	85	120	173	229	279
6	19	52	103	156	249	354	511	677	823
8	34	91	180	274	438	622	899	1190	1447
10	58	156	307	467	748	1061	1533	2029	2467
12	79	212	418	635	1016	1442	2082	2757	3352
14	103	283	553	850	1362	1933	2791	3695	4495
16	126	345	673	1035	1659	2354	3400	4500	5475
18	176	483	942	1448	2321	3294	4757	6297	7660
20	205	561	1095	1683	2698	3829	5530	7320	8905
24	314	859	1677	2577	4131	5863	8467	11208	13635

Valve weight

Valve Size	Wafer	Lug
3	27	39
4	40	57
6	68	122
8	127	219
10	249	398
12	337	580
14	505	860

For weights of valves 16 through 24 inches, contact Xomox Sales Office.

Pressure/Temperature Ratings For Various Seat Materials

Body pressure/temperature ratings are in accordance with ANSI B16.34

Carbon steel body Stainless steel body Seat type

Below 800°F - 17-4 PH shaft

Above 800°F - Inconel shaft

Inconel shaft

Soft seated valves, Class 150

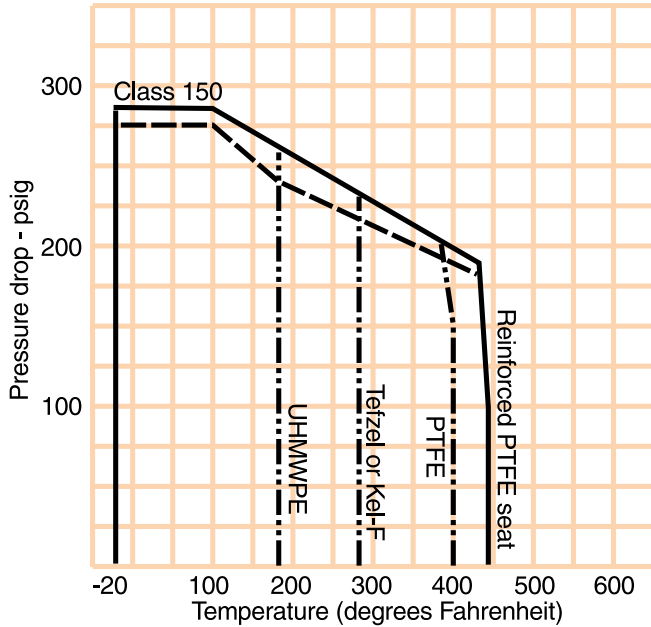

Fire tested and high temperature valves, Class 150

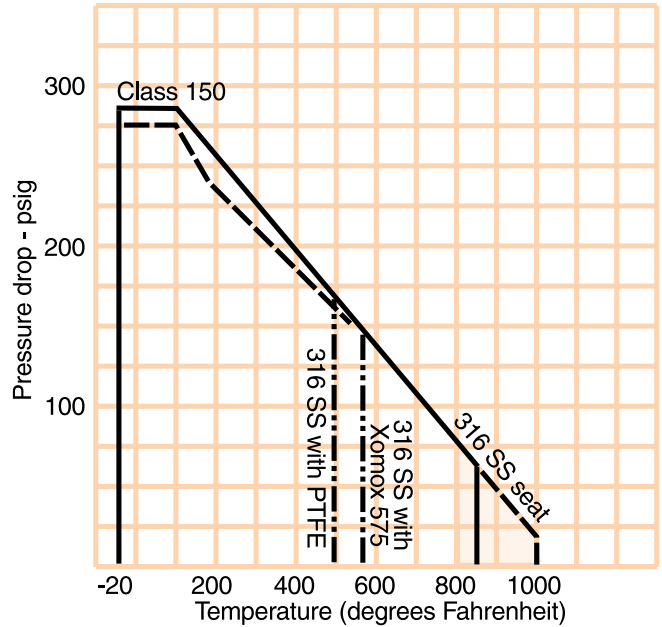

Soft seated valves, Class 300

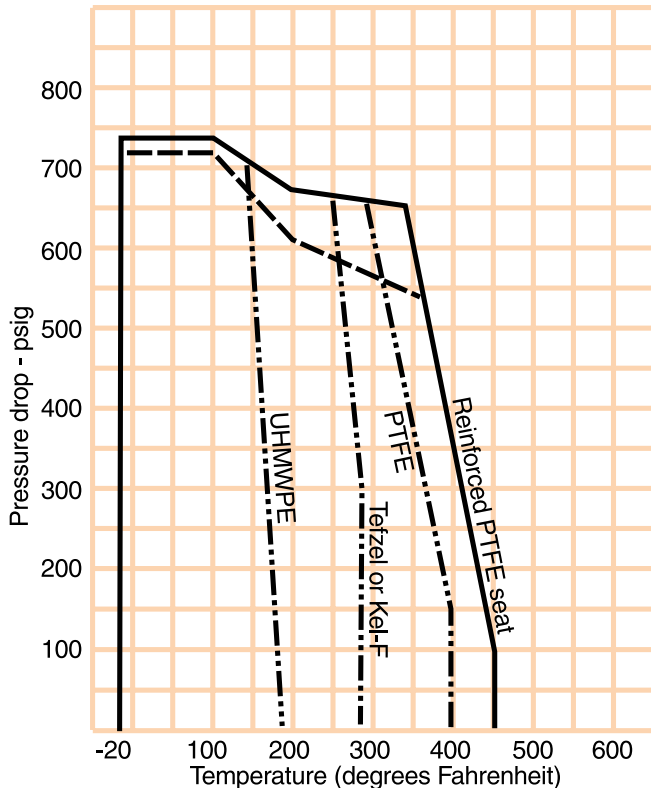

Fire tested and high temperature valves, Class 300

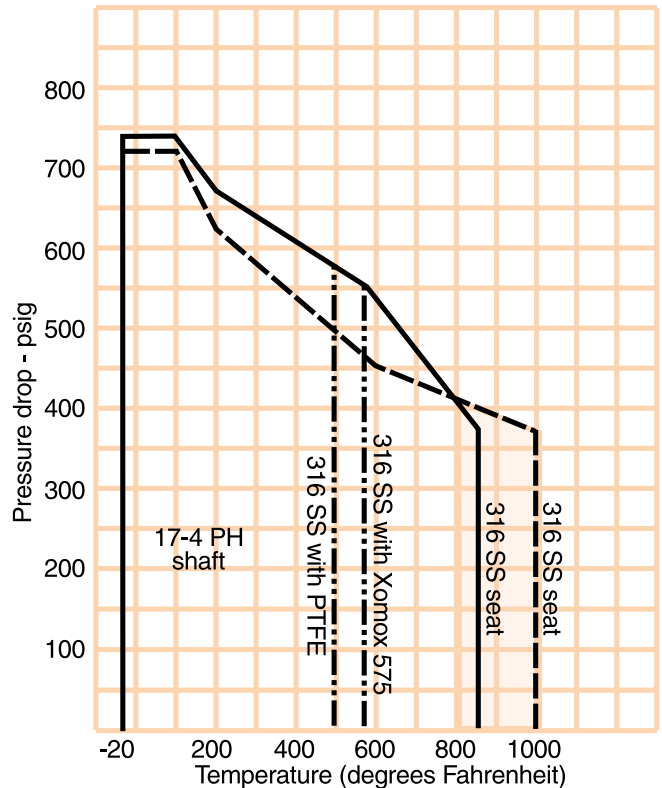

Carbon steel body Stainless steel body Seat type

Below 800°F - 17-4 PH shaft

Above 800°F - Inconel shaft

Inconel shaft

Soft seated valves, Class 600

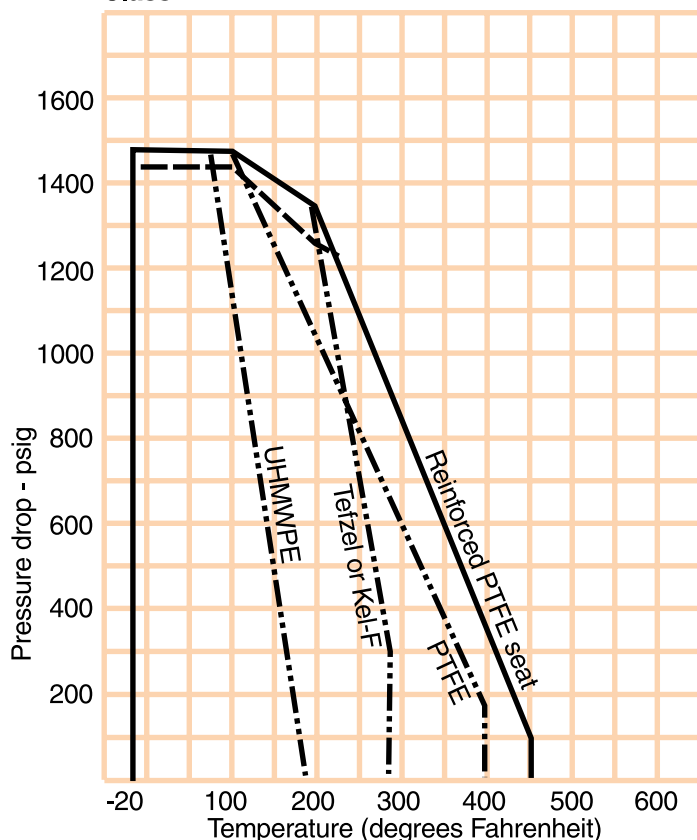

Fire tested and high temperature valves, Class 600

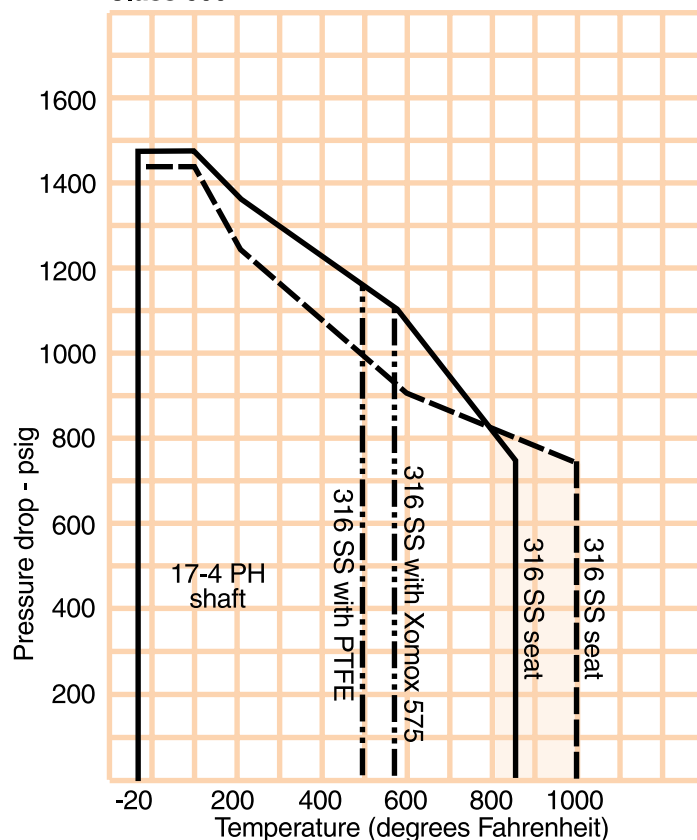

Seat performance data

Seat Type	Maximum Temperature	Minimum Temperature	Test Leak Rate
ST1	400°F	-50°F	ZERO
ST2	450°F	-50°F	ZERO
ST3	180°F	-20°F	ZERO
ST6	250°F	-20°F	ZERO
FT1	500°F	-50°F	ZERO
HT1	1000°F	-50°F	10% of CL IV
ST20	600°F	-20°F	ZERO
FT20	600°F	-20°F	ZERO

Temperature limits of other components

Bearings	PTFE/316 SS (T): -50°F to +450°F
	316/SS/TM treated: -50°F to +1000°F
Packing	PTFE V-rings: -50°F to +450°F
	Graphite: -50°F to +1000°F
Shafts	17-4PH cond. 1075 -20°F to +800°F
	17-4PH cond. 1150-M -50°F to +800°F
Gears	Aluminum housing: Ambient temp. -20°F to +200°F
	Aluminum housing: Max. pipeline temp. +300°F
	Ductile iron housing: Ambient temp. -20°F to +200°F
	Ductile iron housing: Max. pipeline temp. +450°F

Note: Valves with reinforced PTFE (ST2) seats and PTFE/ 316 SS bearings can be used in saturated steam service up to 135 psia and 350°F. Valves with Xomox 575 (HT2) seats and 316 SS/TM treated bearings can be used for saturated and super-heated steam applications up to 575°F.

See Xomox Bulletin 334251 for details on the new **XENITH XT** soft seated and FT seated High performance Butterfly Valves for extended temperature applications.

Breakaway and seating torque values for actuator sizing. Values are in inch-pounds.

ASME Class 150 / 285△P

Valves with PTFE and reinforced PTFE seats							Valves with fire-tested and high temperature seats						
Valve Size	Pressure drop across closed valve (PSI)						Valve Size	Pressure drop across closed valve (PSI)					
	Seat Upstream			Seat Downstream				Seat Upstream			Seat Downstream		
	0 - 100	200	285	0 - 100	200	285		0 - 100	200	285	0 - 100	200	285
2	68	88	108	85	110	135	2	232	300	372	290	375	465
3	132	168	200	165	210	250	3	472	616	760	590	770	950
4	216	272	332	270	340	415	4	504	648	800	630	810	1,000
5	248	616	736	310	770	920	5	920	1,200	1,612	1,150	1,500	2,015
6	528	664	808	660	830	1,010	6	1,400	2,104	3,000	1,750	2,630	3,750
8	1,000	1,256	1,536	1,250	1,570	1,920	8	3,280	3,760	4,200	4,100	4,700	5,250
10	1,600	2,008	2,456	2,000	2,510	3,070	10	4,320	5,768	7,344	5,400	7,210	9,180
12	2,384	3,008	3,656	2,980	3,760	4,570	12	6,624	9,400	12,600	8,280	11,750	15,750
14	4,160	5,200	6,360	5,200	6,500	7,950	14	11,640	12,344	12,952	14,550	15,430	16,190
16	5,680	7,120	8,816	7,100	8,900	11,020	16	13,428	15,192	16,328	16,785	18,990	20,410
18	7,120	9,000	11,248	8,900	11,250	14,060	18	19,920	21,360	22,800	24,900	26,700	28,500
20	9,120	11,600	14,408	11,400	14,500	18,010	20	25,512	27,528	29,600	31,890	34,410	37,000
24	14,480	18,400	22,712	18,100	23,000	28,390	24	40,512	43,672	46,360	50,640	54,590	57,950

ASME Class 300 / 740△P

Valve Size	Valves with PTFE and reinforced PTFE seats - Pressure drop across closed valve (PSI)													
	Seat Upstream							Seat Downstream						
	0 - 100	200	285	400	500	600	740	0 - 100	200	285	400	500	600	740
3	168	216	256	312	360	408	472	210	270	320	390	450	510	590
4	272	352	424	520	608	688	808	340	440	530	650	760	860	1,010
6	672	848	1,032	1,312	1,588	1,800	2,144	840	1,060	1,290	1,640	1,985	2,250	2,680
8	1,280	1,600	1,960	2,520	3,008	3,496	4,176	1,600	2,000	2,450	3,150	3,760	4,370	5,220
10	2,040	2,560	3,136	4,064	4,872	5,680	6,808	2,550	3,200	3,920	5,080	6,090	7,100	8,510
12	3,040	3,840	4,672	6,096	7,328	8,560	10,280	3,800	4,800	5,840	7,620	9,160	10,700	12,850
14	4,440	6,016	7,392	9,568	11,464	13,352	16,000	5,550	7,520	9,240	11,960	14,330	16,690	20,000
16	6,720	8,168	12,080	15,904	19,224	22,544	27,200	8,400	10,210	15,100	19,880	24,030	28,180	34,000
18	7,704	11,240	14,440	19,080	23,112	27,152	32,800	9,630	14,050	18,050	23,850	28,890	33,940	41,000
20	10,600	15,560	20,104	26,744	32,528	38,304	46,400	13,250	19,450	25,130	33,430	40,660	47,880	58,000
24	16,920	23,960	30,696	40,928	49,832	58,736	71,200	21,150	29,950	38,370	51,160	62,290	73,420	89,000

Valve Size	Valves with fire-tested and high-temperature seats - Pressure drop across closed valve (PSI)													
	Seat Upstream							Seat Downstream						
	0-100	200	285	400	500	600	740	0-100	200	285	400	500	600	740
3	472	616	760	824	880	952	1040	590	770	950	1,030	1,100	1,190	1,300
4	504	648	800	920	1,040	1,184	1,400	630	810	1,000	1,150	1,300	1,480	1,750
6	1,400	2,104	3,000	3,208	3,408	3,616	3,960	1,750	2,630	3,750	4,010	4,260	4,520	4,950
8	3,280	3,760	4,200	4,816	5,464	6,160	7,360	4,100	4,700	5,250	6,020	6,830	7,700	9,200
10	4,320	5,768	7,344	7,992	8,568	9,184	10,080	5,400	7,210	9,180	9,990	10,710	11,480	12,600
12	6,624	9,400	12,600	13,504	14,256	15,016	16,200	8,280	11,750	15,750	16,880	17,820	18,770	20,250
14	12,424	14,280	15,072	19,504	23,352	27,200	32,600	15,530	17,850	18,840	24,380	29,190	34,000	40,750
16	18,792	19,384	24,616	32,400	39,176	45,944	55,424	23,490	24,230	30,770	40,500	48,970	57,430	69,280
18	21,544	26,680	29,424	38,880	47,096	55,320	66,832	26,930	33,350	36,780	48,600	58,870	69,150	83,540
20	29,656	36,936	40,960	54,504	66,288	78,064	94,560	37,070	46,170	51,200	68,130	82,860	97,580	118,200
24	47,336	56,880	62,544	83,440	101,600	120,000	145,120	59,170	71,100	78,180	104,300	127,000	150,000	181,400

Breakaway and seating torque values for actuator sizing. Values are in inch-pounds.

ASME Class 600 / 1,480 Δ P

Valve Size	Valves with PTFE and reinforced PTFE seats - Pressure drop across closed valve (PSI)													
	Seat Upstream							Seat Downstream						
	0-200	400	600	740	1,000	1,200	1,480	0-200	400	600	740	1,000	1,200	1,480
3	320	360	456	528	688	824	992	400	450	570	660	860	1,030	1,240
4	496	648	824	968	1,264	1,480	1,816	620	810	1,030	1,210	1,580	1,850	2,270
6	1,048	1,368	1,848	2,232	2,728	3,208	3,936	1,310	1,710	2,310	2,790	3,410	4,010	4,920
8	1,760	2,648	3,616	4,384	5,280	6,512	7,672	2,200	3,310	4,520	5,480	6,600	8,140	9,590
10	5,464	6,768	8,120	9,456	12,064	14,360	16,888	6,830	8,460	10,150	11,820	15,080	17,950	21,110
12	6,784	9,320	12,424	15,096	19,280	22,760	27,016	8,480	11,650	15,530	18,870	24,100	28,450	33,770
14	10,632	14,640	16,616	23,496	30,008	34,160	38,000	13,290	18,300	20,770	29,370	37,510	42,700	47,500
16	18,072	24,888	28,248	39,944	51,016	58,072	64,600	22,590	31,110	35,310	49,930	63,770	72,590	80,750
18	21,800	30,024	34,072	48,176	61,532	70,048	77,920	27,250	37,530	42,590	60,220	76,915	87,560	97,400
20	30,840	42,472	48,200	68,160	87,040	99,120	110,240	38,550	53,090	60,250	85,200	108,800	123,900	137,800
24	47,320	65,160	73,952	104,560	133,520	152,000	169,120	59,150	81,450	92,440	130,700	166,900	190,000	211,400

Valve Size	Valves with fire-tested and high temperature seats - Pressure drop across closed valve (PSI)													
	Seat Upstream							Seat Downstream						
	0-200	400	600	740	1,000	1,200	1,480	0 - 200	400	600	740	1,000	1,200	1,480
3	672	872	968	1,136	1,264	1,520	1,816	840	1,090	1,210	1,420	1,580	1,900	2,270
4	752	1,032	1,288	1,536	1,824	2,136	2,624	940	1,290	1,610	1,920	2,280	2,670	3,280
6	2,168	3,344	3,720	4,096	4,288	4,944	6,064	2,710	4,180	4,650	5,120	5,360	6,180	7,580
8	4,136	5,072	6,376	7,728	9,304	11,480	13,520	5,170	6,340	7,970	9,660	11,630	14,350	16,900
10	10,240	11,096	13,120	14,000	16,080	19,120	22,480	12,800	13,870	16,400	17,500	20,100	23,900	28,100
12	13,840	17,200	18,160	19,840	25,320	29,888	35,480	17,300	21,500	22,700	24,800	31,650	37,360	44,350
14	18,440	24,520	28,056	33,880	39,408	44,856	49,904	23,050	30,650	35,070	42,350	49,260	56,070	62,380
16	31,360	41,680	47,680	57,600	66,960	76,240	84,800	39,200	52,100	59,600	72,000	83,700	95,300	106,000
18	37,840	50,280	57,520	69,440	80,800	92,000	102,320	47,300	62,850	71,900	86,800	101,000	115,000	127,900
20	53,520	71,120	81,360	98,240	114,400	130,160	144,800	66,900	88,900	101,700	122,800	143,000	162,700	181,000
24	82,080	109,120	124,880	150,800	175,360	199,600	222,080	102,600	136,400	156,100	188,500	219,200	249,500	277,600

The sizing of an actuator is dependent on several variables: pressure drop, seat, packing, and bearing materials, available air pressure, closing speed, and media.

The following torque values are based on the assumption of clean, clear fluid, at ambient temperature, and standard bearing and packing materials.

Notes

1. For valve seats made of UHMWPE (ST3), add 20% to the torque values listed for PTFE and reinforced PTFE seats.
2. For valve seats made of 316 SS / Xomox 575 (HT2), add 30% to the torque values listed for fire-tested and high temperature seats.
3. Consult factory for Δ P limitations on shaft materials other than 17-4PH SS.

Valve components - General second generation exploded view diagram.
 Components and quantities may vary based on valve size, pressure class, or body style.

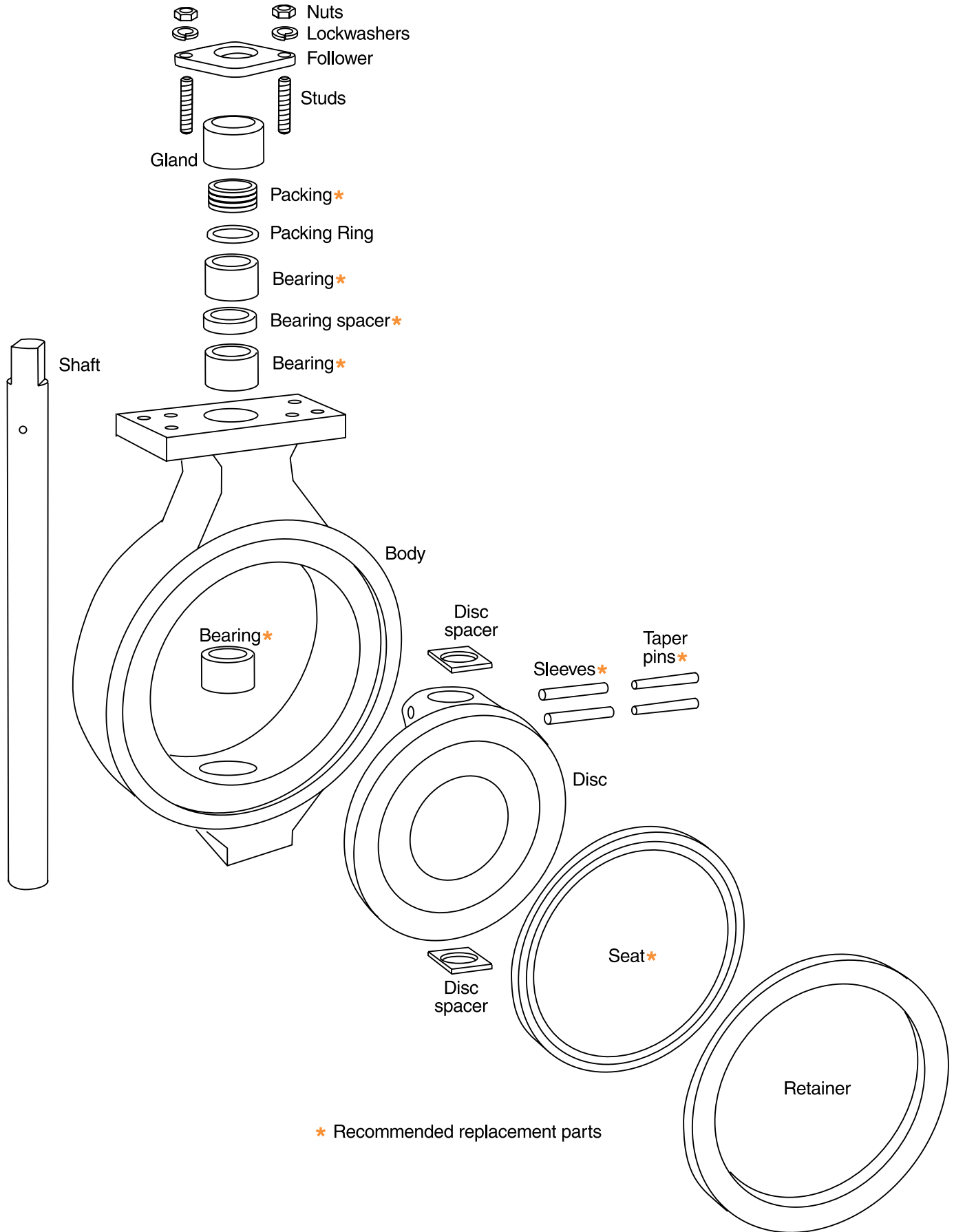

Standard Materials Of Construction.

Soft seated valves

Part Description	Carbon/316	316/316
Body ¹	Cast: A216 Gr. WCB ⁴ Forging: A105 ⁴ Plate: A515 Gr. 70 ^{2, 4}	A351 Gr. CF8M
Disc ¹	Cast: A351 Gr. CF8M Forging: A182 Gr. F316	Cast: A351 Gr. CF8M Forging: A182 Gr. F316
Retainer ¹	A515 Gr. 70 carbon steel ^{2, 4}	A240 Type 316 stainless steel
Follower	A216 Gr. WCB ⁴ or C1018 carbon	A351 Gr. CF8M or 316 stainless steel
Follower stud	A193 B7	A193 B8
Follower nut	A194 2H	A194 Gr.8
Lockwasher	Carbon steel ⁷	302 stainless steel
Disc spacer ¹	A747 Grade CB-7CU or A351 Gr. CF8M ⁵	
Taper pin ¹	Nitronic 50 or 316 stainless steel	
Hollow pin ¹	316 stainless steel	
Bearing ¹	Fiberglass/PTFE with 316 stainless steel backing	
Shaft ¹	17-4 PH stainless steel	
Seat ¹	Reinforced PTFE	
Membrane	Fiberglass/PTFE	
Retainer screws ¹	A193 B8MA Class 1	
Packing ¹	PTFE	
Packing ring ¹	316 stainless steel	
Gland	316 stainless steel	
Plug/sealing cap ^{1, 3, 8}	C 1020 carbon steel ⁶	316 stainless steel
Plug seal ^{1, 3, 8}	PTFE	
Stop ring ^{3, 8}	C4130 carbon steel ⁴	
High collar lockwasher ^{3, 8}	Carbon steel ⁶	
Roll pin ^{3, 8}	Carbon steel ⁶	
Follower screw ^{3, 8}	C1035 carbon steel ⁶	

High temperature & fire tested valves

Part Description	Carbon/316	316/316
Body ¹	Cast: A216 Gr. WCB ⁴ Forging: A105 ⁴ Plate: A515 Gr. 70 ^{2, 4}	A351 Gr. CF8M
Disc ¹	Cast: A351 Gr. CF8M ⁹ Forging: A182 Gr. F316 ⁹	Cast: A351 Gr. CF8M ⁹ Forging: A182 Gr. F316 ⁹
Retainer ¹	A515 Gr. 70 carbon steel ^{2, 4}	A240 Type 316 stainless steel
Follower	A216 Gr. WCB ⁴ or C1018 carbon	A351 Gr. CF8M or 316 stainless steel
Follower stud	A193 B7	A193 B8
Follower nut	A194 2H	A194 Gr.8
Lockwasher	Carbon steel ⁷	302 stainless steel
Disc spacer ¹	A747 Grade CB-7CU or A351 Gr. CF8M ⁵	
Taper pin ¹	Nitronic 50 or 316 stainless steel	
Hollow pin ¹	316 stainless steel	
Bearing ¹	316 stainless steel ⁹	
Shaft ¹	17-4 PH stainless steel	
Seat ¹	316 stainless steel with PTFE, 316 stainless steel	
Seat gasket ¹	Reinforced graphite	
Retainer screws ¹	A193 B8MA Class 1	
Packing ¹	Reinforced graphite	
Packing ring ¹	316 stainless steel	
Gland	316 stainless steel	
Plug/sealing cap ^{1, 3, 8}	C 1020 carbon steel ⁶	316 stainless steel
Plug seal ^{1, 3, 8}	Grafoil	
Stop ring ^{3, 8}	C4130 carbon steel ⁴	
High collar lockwasher ^{3, 8}	Carbon steel ⁶	
Roll pin ^{3, 8}	Carbon steel ⁶	
Follower screw ^{3, 8}	C1035 carbon steel ⁶	

1. Wetted parts.
2. A516 Gr. 70 available on request.
3. For valves with 2-inch diameter shaft or larger.
4. Black oxide coated.
5. Chrome plating.
6. Cadmium plating.
7. Zinc plating.
8. 14-inch to 24-inch Class 150/300 and 3-inch to 24-inch Class 600 valves only.
9. Electroless NiCu plating.

Below is an example of the Tufline High Performance Butterfly Valve ordering code:

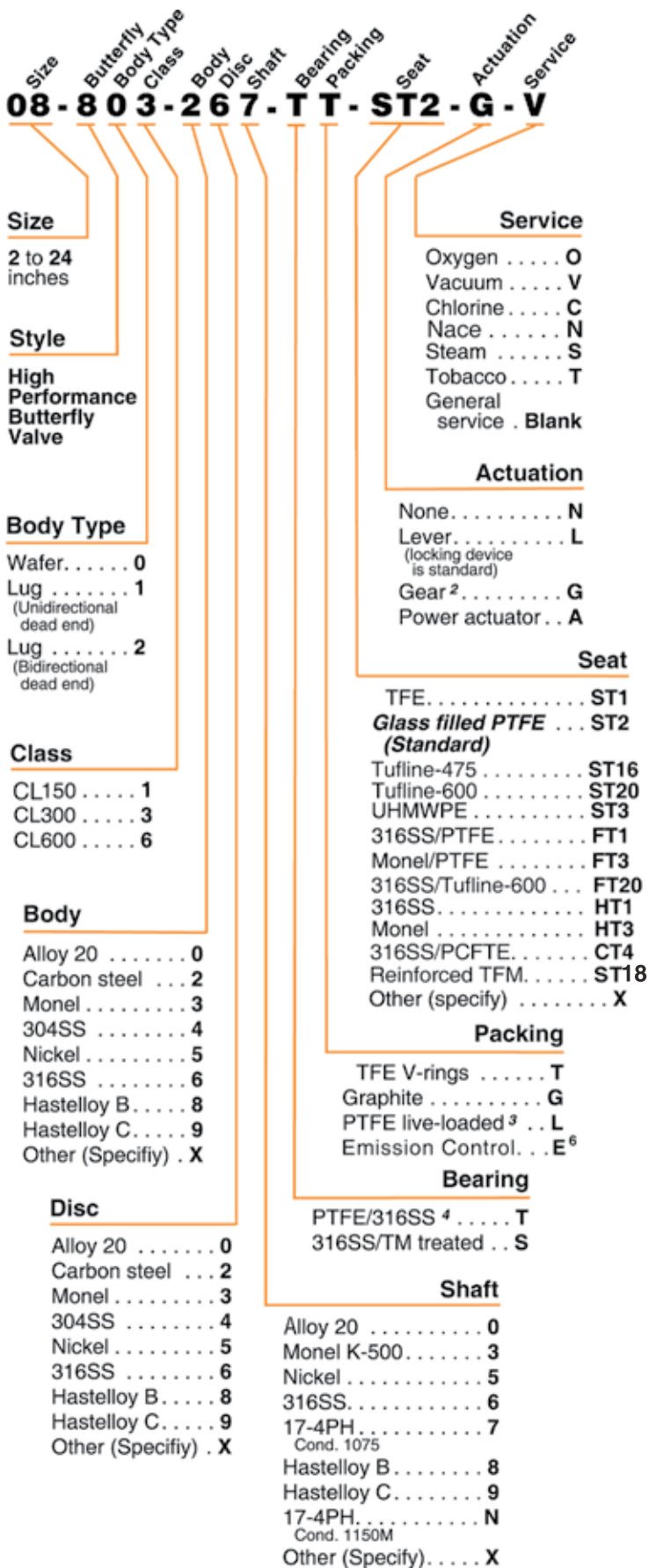

General Notes:

- 1 - API 609 face to face dimensions are standard. Any other face to face requirements must be specified.
- 2 - Aluminum gear maximum 300°F line temperature. Use DI above 300°F.
- 3 - Single set. For double set with leak-off consult factory. Not to be used when lever actuator is required.
- 4 - 350°F maximum in steam service.
- 5 - Consult factory for ΔP limitations on shaft materials other than 17-4 PH.
- 6 - Double length (XP) extended packing (TFE) with live-loading bevel washers and monitoring port.

For information on 30" - 48" Tufline High Performance Butterfly Valves, see Xomox Brochure 335251.

For sizes and materials not shown, consult factory.

⚠ WARNING

For bi-directional dead end service, you must use body type 821, or 823 valves. These valves have retainers specially designed for such service. Use of body type 811, 813, or 816 valves in such service will result in massive leakage.



CRANE ChemPharma, Xomox & Matryx® Actuators.

Tufline Valves are available as part of a complete valve package.

Actuators are available in three models:

- Double acting vane
- Rack & pinion spring return
- Electric

Tufline automated valve packages assure you of single-source responsibility for flow control equipment.

With Tufline valves, Matryx and Xomox actuators, Xomox control accessories, and Tufline problem solving expertise, you are assured of valve packages that will provide optimum performance in your application.

Solid performance data means processors can size actuators with more of a confidence factor and less of a “fudge-factor”. Initial cost, repair costs, replacement costs, and costly downtime can all be reduced.

Rack and pinion actuators are available in both double-acting and spring-return models with both 90° and 180° rotation.



CRANE ChemPharma, Xomox Automation & Service Centers.

Strategically located Xomox Automation & Service Centers provide a variety of services. These range from standard repair to major modification and accessory packaging.



XOMOX®

CRANE ChemPharma Flow Solutions™

XOMOX Headquarters
4444 Cooper Road,
Cincinnati, OH 45242, U.S.A.
Tel.: (513) 745-6000
Fax: (513) 745-6086

XOMOX International GmbH & Co. OHG
Von-Behring-Straße 15,
D-88131 Lindau/Bodensee
Tel.: (49) 8382-702-0
Fax: (49) 8382-702-144

CRANE

ChemPharma Flow Solutions



brands you trust.

CRANE ChemPharma Flow Solutions Include: Pipe - Valves - Fitting - Actuators - Pumps



CP-XOMOX-HPBV-BU-EN-CI-4/10-PN329389

Crane Co., and its subsidiaries cannot accept responsibility for possible errors in catalogues, brochures, other printed materials, and website information. Crane Co. reserves the right to alter its products without notice, including products already on order provided that such alteration can be made without changes being necessary in specifications already agreed. All trademarks in this material are property of the Crane Co. or its subsidiaries. The Crane and Crane brands logotype (Xomox®, Saunders®, Resistoflex®, Resistopure™, PSI®, DEPA®, ELRO®, REVO®) are registered trademarks of Crane Co. All rights reserved.